

DRAFT

AUTOMOTIVE INDUSTRY STANDARD

**Provisions of motor vehicle headlamps emitting
a symmetrical passing beam or a driving beam
or both and equipped with filament, gas-
discharge light sources or LED Modules**

(Revision 2)

ARAI

**Date of hosting on website: 7th August 2017
Last date for comments: 6th September 2017**

Status chart of the standard to be used by the purchaser for updating the record

Sr. No.	Corrigenda.	Amendment	Revision	Date	Remark	Misc.
General Remarks						

INTRODUCTION

0. The Government of India felt the need for a permanent agency to expedite the publication of standards and development of test facilities in parallel when the work on the preparation of the standards is going on, as the development of improved safety critical parts can be undertaken only after the publication of the standard and commissioning of test facilities. To this end, the erstwhile Ministry of Surface Transport (MOST) has constituted a permanent Automotive Industry Standards Committee (AISC) vide order No. RT-11028/11/97-MVL dated September 15, 1997. The standards prepared by AISC will be approved by the permanent CMVR Technical Standing Committee (CMVR-TSC). After approval, the Automotive Research Association of India, (ARAI), Pune, being the Secretariat of the AIS Committee, will publish this standard. For better dissemination of this information ARAI may publish this document on their Web site..
- 0.1 Accordingly AIS-010 covering mandatory requirements regarding performance of lighting and light signaling devices for use in two and three wheelers has been published in 2004 and has been implemented thereafter in 2005. This standard is then published under Revision 1 in 2010 to include amendments of ECE Regulation No.113.
- 0.2 With technological developments in lighting and light signaling devices, this part is taken up for revision. This part covers the Approval of headlamps emitting an symmetrical passing beam or a driving beam or both and equipped with filament lamps, Gas-Discharge Light Sources or LED modules as applicable to motor vehicles. The permission to use headlamps covered by this standard for a vehicle category is governed by requirements specified by the standard for installation of requirements of that category of vehicles.
- 0.3 This part is based on ECE Regulation No.113 - Rev.3 - Supplement 05 to the 01 series of amendments – (Date of entry into force: 8 October 2015).
- 0.4 While preparing this standard attempts have been made to align with the above ECE regulation. However, certain changes were necessary in the Indian context.
- 0.5 The following standards contain provisions, which through reference in this text constitute provisions of the standard.

AIS-008(Rev.1)	Installation Requirements of Lighting and Light –Signalling Devices for Motor Vehicle having more than Three Wheels, Trailer and Semi -Trailer excluding Agricultural Tractor and Special Purpose Vehicle
AIS-009	Automotive Vehicles - Installation Requirements of Lighting and Light - Signalling Devices for 2 and 3 Wheelers, their Trailers and Semi-Trailers
AIS-053	Automotive Vehicles – Types – Terminology
AIS-004 (Part 3)	Automotive Vehicles – Requirements for Electromagnetic compatibility

- | | |
|---|---|
| AIS-010 (Part 5)
(Rev. 2) | Requirements of Chromaticity co-ordinates of light emitted from Lighting and Light-Signalling Devices |
| AIS-010 (Part 1)
(Rev. 2) | Provisions concerning the Approval of Headlamps Emitting an Asymmetrical Passing Beam or a Driving Beam or both and equipped with Filament Lamps and/or LED Modules |
| AIS-034 (Part 1)
(Rev. 1) | Provisions concerning the Approval of Filament Lamps for use in Approved Lamp Units on Power Driven Vehicles and their Trailers |
| AIS-034 (Part 2)
(Rev. 1) | Provisions concerning the Approval of Gas discharge Light Sources for use in approved Gas Discharge Lamp Units of Power Driven Vehicles |
| AIS-037 | Procedure for Type Approval and Establishing Conformity of Production for Safety Critical Components AIS-053 Automotive Vehicles – Types – Terminology |
| AIS-012 | Performance Requirements of Lighting and Light Signalling Devices for Motor Vehicle having more than Three wheels, Trailer and Semi-trailer |
| IEC Publication
61-2, third
edition, 1969 | Lamp Caps and Holders together with Gauges for the Control of Interchangeability and Safety- Part 2: Lamp Holders. |
| IEC Publication
60061 | Lamp Caps and Holders together with Gauges for the Control of Interchangeability and Safety. |
| 0.6 | The AISC panel responsible for formulation of this standard is given in Annex ## |
| 0.7 | The Automotive Industry Standards Committee (AISC) responsible for approval of this standard is given in Annex ## |

Paragraph Nos.	Contents	Page No
0	Scope	
1	Definitions	
2	Application for Approval of Headlamp	
3	Markings	
4	Approval	
5	General Specifications	
6	Illumination	
7	Colour	
8	Extension of Type Approval	
9	Conformity of Production	
10	Penalties for Non-Conformity of Production	
11	Reserved paragraph	
12	Reserved paragraph	
13	Transitional provisions	
14	Establishing compliance of “E”/“e” approved retro Head Lamp to this standard	
15	Amendments to ECE regulations after the level described in 0.3 of foreword	
ANNEXES		
Annex A	Information and samples to be submitted at the time of type approval	
Annex B	Reserved Annexure	
Annex C	Spherical Coordinate Measuring System and Test Point Locations	
Annex D	Tests for Stability of Photometric Performance of Headlamps in operation - Tests on complete class B, C, D and E Headlamps	
Annex E	Minimum Requirements for Conformity of Production Control Procedures	
Annex F	Requirements for lamps incorporating lenses of plastic material - Testing of lens or material samples and of complete Headlamps	
Annex G	Minimum Requirements for Sampling by Testing Agency	

Annex Nos.	Contents	Page No
Annex H	Overview of operational periods concerning test for Stability of Photometric Performance	
Annex J	Definition and sharpness of the "cut-off" line for symmetrical passing-beam headlamps and aiming procedure by means of this "cut-off" line	
Annex K	Centre of Reference	
Annex L	Voltage Markings	
Annex M	Requirements for LED modules and Headlamps Including LED Modules	

CHECK LIST FOR PREPARING AUTOMOTIVE INDUSTRY STANDARD

Draft AIS-010 (Part 2) (Rev.2)

**PROVISIONS OF MOTOR VEHICLE HEADLAMPS EMITTING A
SYMMETRICAL PASSING BEAM OR A DRIVING BEAM OR BOTH AND
EQUIPPED WITH FILAMENT, GAS-DISCHARGE LIGHT SOURCES OR LED
MODULES**

SR. NO.	PARTICULARS	REMARKS
1.	Indicate details of the base reference standard. (eg. ECE / EEC Directive/GTR etc.)	ECE Regulation No.113 - Rev.3 - Supplement 05 to the 01 series of amendments – (Date of entry into force: 8 October 2015
2.	Add an explanatory note indicating differences between the above standard and the draft, if any.	1. Cross references to respective Indian Standards. (e.g. AIS) 2. Marking requirements. 3. Transitional provisions. 4. Administrative provisions, e.g. Type approval & extension of approvals.
3.	Specify details of technical specifications to be submitted at the time of type approval relevant to the requirements of this standard covered.	As per Annex A
4.	Are the details of Worst Case Criteria covered?	Yes
5.	Are the performance requirements covered?	Yes
6.	Is there a need to specify dimensional requirements?	Yes.
7.	If yes, are they covered?	Yes
8.	Is there a need to specify COP requirements? If yes, are they covered?	Yes. Yes
9.	Is there a need to specify type approval, and routine test separately, as in the case of some of the Indian Standards? If yes, are they covered?	Not required.
10.	If the standard is for a part/component or sub- system; i) AIS-037 or ISI marking scheme be implemented for this part? ii) Are there any requirements to be covered for this part when fitted on the vehicle? If yes, has a separate standard been prepared?	i) Yes ii) Not required

11.	If the standard is intended for replacing or revising an already notified standard, are transitory provisions for re-certification of already certified parts/vehicles by comparing the previous test result, certain additional test, etc. required? If yes, are they included?	Yes, Provisions included in clause 13.
12.	Include details of any other international or foreign national standards which could be considered as alternate standard.	No, However further Amendments/ Supplements / corrigendum to ECE R 113 may be considered for certification. Provisions included in clause 15.
13.	Are the details of accuracy and least counts of test equipment/meters required to be specified? If yes, have they been included?	Yes. Included.
14.	What are the test equipment for establishing compliance?	As specified in this standards
15.	If possible, identify such facilities available in India.	Test agencies to confirm.
16.	Are there any points on which special comments or information is to be invited from members? If yes, are they identified?	Comments / discussion required on yellow highlighted points.
17.	Does the scope of standard clearly identify vehicle categories?	Yes
18.	Has the clarity of definitions been examined?	Yes

PROVISIONS OF MOTOR VEHICLE HEADLAMPS EMITTING A
SYMMETRICAL PASSING BEAM OR A DRIVING BEAM OR BOTH AND
EQUIPPED WITH FILAMENT, GAS-DISCHARGE LIGHT SOURCES OR LED
MODULES

(Aligned with ECE Regulation No.113 - Rev.3 - Supplement 05 to the 01 series of amendments – (Date of entry into force: 8 October 2015))

Clause No. Clause as compared with AIS-010 (Part 2) (Rev.1):2010 – changes are marked blue.

0 SCOPE

This standard lays down the performance requirements of headlamps emitting an symmetrical passing beam or a driving beam or both and equipped with filament lamps, or Gas-Discharge Light Sources or LED Modules for L and A categories of vehicles as defined in AIS-053.

Note: The permission to use headlamps covered by this standard are governed by requirements specified by the standard for installation of requirements of that category of vehicles.

1. DEFINITIONS

In addition to the following definition, the definitions given in AIS-008, AIS-009, AIS-010 (Part 5) and their amendments in force at the time of application for type approval shall apply to this standard.

1.1 "Lens" means the outermost component of the headlamp (unit) which transmits light through the illuminating surface;

1.2 "Coating" means any product or products applied in one or more layers to the outer face of a lens;

1.3 "Headlamps of different types" mean headlamps which differ in such essential respects as:

1.3.1 The trade name or mark;

1.3.2 The characteristics of the optical system;

1.3.3 The inclusion or elimination of components capable of altering the optical effects by reflection, refraction, absorption and/or deformation during operation;

1.3.4 The kind of beam produced (passing beam, driving beam or both);

1.3.5 The category of filament or gas-discharge light source; or the light source module specific identification code(s);

1.4 "Headlamps of different "Classes" (A or B or C or D or E)" mean headlamps identified by particular photometric provisions.

- 1.5 **"Colour of the light emitted from the device". The definitions of the colour of the light emitted given in, AIS-010 (Part 5) (Rev.2).**
- 1.6 However, in the case of a system consisting of two headlamps a device intended for the installation on the left side of the vehicle and the corresponding device intended for the installation on the right side of the vehicle shall be considered to be of the same type.
- 1.7 **References made in this standard to standard (étalon) filament lamp(s) shall refer to AIS 034 (Part 1) (Rev.2).**
- 1.8 **References made in this standard to standard (étalon) gas discharge light sources(s) shall refer to AIS 034 (Part 2) (Rev.2).**
- 1.9 **"Additional lighting unit" means the part of a headlamp system that provides the bend lighting. It is independent from the device that provides the principal passing beam, may consist of optical, mechanical and electrical components, and it may be grouped and/or reciprocally incorporated with other lighting or light-signalling devices.**
- 1.10 **Other relevant definitions given in AIS 008 (Rev.1) and AIS 009 (Rev.2) shall apply.**

2. APPLICATION FOR APPROVAL OF HEADLAMP

- 2.1. Information to be submitted at the time of applying for type approval of the headlamp shall be as given in Annex A.
 - 2.1.1. Reserved
 - 2.1.2. Reserved
 - 2.1.3. Reserved.
 - 2.1.4. Reserved
- 2.2 Every application for approval shall be accompanied by
 - 2.2.1. Reserved
 - 2.2.2. Reserved
 - 2.2.3. Two samples of the type of headlamp; In the case of a system consisting of two headlamps one sample intended for the installation on the left side of the vehicle and one sample intended for the installation on the right side of the vehicle;
 - 2.2.4. For Class B or C or D or E headlamps only, for the test of plastic material of which the lenses are made:
 - 2.2.4.1. For Class B or C or D **or E, fourteen** lenses;

- 2.2.4.1.1 For Class B or C or D, **or E Ten** of these lenses may be replaced by **Ten** samples of material at least 60 x 80 mm in size, having a flat or convex outer surface and a substantially flat area (radius of curvature not less than 300 mm) in the middle measuring at least 15 x 15 mm;
- 2.2.4.1.2 Every such lens or sample of material shall be produced by the method to be used in mass production;
- 2.2.4.2. A reflector to which the lenses can be fitted in accordance with the manufacturer's instructions.
- 2.2.5. **For headlamps equipped with light sources according to AIS 034 (Part 2) (Rev.2) or equipped with LED modules** only, for testing the UV-resistance of light transmitting components made of plastic material against UV radiation of gas-discharge light sources inside the headlamp:
 - 2.2.5.1. One sample each of the relevant material as being used in the headlamp or one headlamp sample containing these. Each material sample shall have the same appearance and surface treatment, if any, as intended for use in the headlamp to be approved.
 - 2.2.5.2. The UV-resistance testing of internal materials to light source radiation is not necessary:
 - 2.2.5.2.1 If low-UV-type gas-discharge light sources are being applied as specified in AIS-034 (Part 2)(Rev.-2) or;
 - 2.2.5.2.2 **If only low-UV-type LED modules, as specified in Annex M of this standard, are being applied, or;**
 - 2.2.5.2.3 If provisions are taken to shield the relevant headlamp components from UV radiation, e.g. by glass filters.
- 2.2.6. **One ballast or electronic light source control gear, as applicable.**
- 2.3. The materials making up the lenses and coatings, if any, shall be accompanied by the test report of the characteristics of these materials and coatings if they have already been tested.
- 3. **MARKINGS**
 - 3.1 Headlamps submitted for approval shall bear the trade name or mark of the headlamp manufacturer.
 - 3.2 They shall comprise, on the lens and on the main body, (See **3.2.1**) spaces of sufficient size for the approval mark and the additional symbols referred to in 4; these spaces shall be indicated on the drawings referred to in A-9 of Annex A.
 - 3.2.1 If the lens cannot be detached from the main body of the headlamp, a unique marking as per 4.2.5 shall be sufficient.

- 3.3 on the back of the headlamp the indication of the category of filament lamp or gas-discharge light source used.
- 3.4 Class E headlamps may bear on their light-emitting surface a centre of reference as shown in Annex K.
- 3.5 Class E headlamps shall bear the voltage markings as shown in Annex L.
- Note** On the prototype for type approval, the markings may be provided by suitable temporary methods and need not necessarily be obtained from the tools used for series production.
- 3.6. In the case of lamps with LED module(s), the lamp shall bear the marking of the rated voltage and rated wattage and the light source module specific identification code.**
- 3.7. LED module(s) submitted along with the approval of the lamp shall bear:**
- 3.7.1. The trade name or mark of the applicant. This marking shall be clearly legible and indelible;**
- 3.7.2. The specific identification code of the module. This marking shall be clearly legible and indelible. This specific identification code shall comprise the starting letters "MD" for "MODULE" followed by the approval marking as prescribed in paragraph 4.2.1. below and in the case several non identical light source modules are used, followed by additional symbols or characters. This specific identification code shall be shown in the drawings mentioned Annex A. The approval marking does not have to be the same as the one on the lamp in which the module is used, but both markings shall be from the same applicant**
- 3.7.3 If the LED module(s) are non-replaceable, the markings for LED module(s) are not required.**
- 3.8. If an electronic light source control gear which is not part of a LED module is used to operate a LED module(s), it shall be marked with its specific identification code(s), the rated input voltage and wattage.**
- 3.9. In the case of additional lighting unit(s), the headlamps producing the principal passing beam shall bear specific identification code of the additional lighting unit(s) mentioned in paragraph 3.10.2. below.**
- 3.10. Additional lighting unit(s) shall bear the following markings:**
- 3.10.1. The trade name or mark of the applicant. This marking shall be clearly legible and indelible.**
- 3.10.2. In the case of filament light source, the category(s) of filament lamp(s), and/or In the case of LED module(s), the rated voltage and rated wattage and the specific identification code(s) of the LED module(s).**

- 3.10.3.** The specific identification code(s) of the additional lighting unit(s). This marking shall be clearly legible and indelible. This specific identification code shall be comprised of starting letters "ALU" for "Additional Lighting Unit" followed by approval marking as prescribed in paragraph 4.2.1. below (ex. ALU E43 1234) and in the case where several non identical additional lighting units are used, additional symbols or characters shall follow (ex. ALU E43 1234-A, ALU E43 1234-B).—This specific identification code shall be shown in the drawings mentioned in Annex A. The approval marking does not have to be the same as the one on the lamp in which the additional lighting unit(s) is used, but both markings shall be from the same applicant.

[Need to discuss LED module marking with respect to AIS 037/ ECE marking]

4 APPROVAL

4.1. General

4.1.1 If all the samples of a type of headlamp submitted pursuant to 2 satisfy the provisions of this standard, approval shall be granted.

4.1.2 Where grouped, combined or reciprocally incorporated lamps satisfy the requirements of more than one part of this standard or other AIS, a single approval mark may be affixed provided that each of the grouped, combined or reciprocally incorporated lamps satisfies the provisions applicable to it.

4.1.3 Reserved

4.1.4 Reserved

4.1.5. In addition to the mark prescribed in 3.1., an approval mark as described in 4.2 and 4.3 below shall be affixed in the spaces referred to in 3.2 above to every headlamp conforming to a type approved under this standard.

4.2 Composition of the approval mark

The approval mark shall consist of:

4.2.1 Approval mark shall be as per AIS-037.

4.2.1.1. Reserved

4.2.1.2. Reserved

4.2.2. the following additional symbol (or symbols):

4.2.2.1 a horizontal arrow with a head on each end, pointing to the left and to the right;

4.2.2.2. On headlamps meeting the requirements of this standard in respect of the

passing beam only, the letters "C-AS" for Class A headlamps
or "C-BS" for Class B headlamps or "WC-CS" for Class C headlamp
or "WC-DS" for Class D headlamp or "WC-ES" for Class E headlamps;

- 4.2.2.3 On headlamps meeting the requirements of this standard in respect of the driving beam only, "R-BS" for Class B headlamps or "WR-CS" for Class C headlamp or "WR-DS" for Class D headlamp or "WR-ES" for Class E headlamps;
- 4.2.2.4 On headlamps meeting the requirements of this standard in respect of both the passing beam and the driving beam, the letters "CR-BS"
- 4.2.2.5. On headlamps incorporating a lens of plastic material, the group of letters "PL" to be affixed near the symbols prescribed in **4.2.1** and **4.2.2** above.
- 4.2.2.6 On headlamps, other than Class A, meeting the requirements of this standard in respect of the driving beam, an indication of the maximum luminous intensity expressed by a reference mark, as defined in **6.3.2.1.2**.
- 4.2.3. In every case the relevant operating mode used during the test procedure according to paragraph D-1.1.1.1. of Annex D and the permitted voltage(s) according to paragraph D-1.1.1.2. of Annex D shall be stipulated on the test report. In the corresponding cases the device shall be marked as follows:
 - 4.2.3.1. On headlamps meeting the requirements of this **standard** which are so designed that the filament lamp, gas-discharge light source **or LED module (s) producing the** passing beam shall not be lit simultaneously with that of any other lighting function with which it may be reciprocally incorporated: an oblique stroke (/) shall be placed behind the passing lamp symbol in the approval mark.
- 4.2.4 Reserved
- 4.2.5. The marks and symbols referred to in paragraphs **4.2.1.** to **4.2.3.** above shall be clearly legible and be indelible. They may be placed on an inner or outer part (transparent or not) of the headlamp, which cannot be separated from the transparent part of the headlamp emitting the light. In any case they shall be visible when the headlamp is fitted on the vehicle or when a movable part is opened.
- 4.3 Arrangement of the approval mark
 - 4.3.1. Independent lamps
 - 4.3.1.1 Annex 2, figures 1 to 12 of the ECE R113, (Supplement **5** to **01 series of amendments** of the regulation) may be used for the relative location of approval marking and other marking.
 - 4.3.2 Grouped, combined or reciprocally incorporated lamps:

- 4.3.2.1 Where grouped, combined or reciprocally incorporated lamps have been found to comply with the requirements of several standards, a single approval mark may be affixed, This approval mark may be located anywhere on the grouped, combined or reciprocally incorporated lamps, provided that:
- 4.3.2.1.1 It is visible as per 4.2.5.
- 4.3.2.1.2 No part of the grouped, combined or reciprocally incorporated lamps that transmits light can be removed without at the same time removing the approval mark.
- 4.3.2.2. The identification symbol for each lamp appropriate to each standard under which approval has been granted, together with the corresponding series of amendments incorporating the most recent major technical amendments to the standard at the time of issue of the approval, and if necessary, the required arrow shall be marked:
- 4.3.2.2.1 Either on the appropriate light-emitting surface.
- 4.3.2.2.2 Or in a group, in such a way that each of the grouped, combined or reciprocally incorporated lamps may be clearly identified.
- 4.3.2.3. The size of the components of a single approval mark shall not be less than the minimum size required for the smallest of the individual marks by the standard under which approval has been granted.
- 4.3.2.4. Reserved
- 4.3.2.5 Annex 2, figure 13 of ECE R113, (Supplement **5** to **01 series of amendments** of the regulation) may be used as examples of arrangements of approval marks for grouped, combined or reciprocally incorporated lamps with all the above mentioned additional symbols.
- 4.3.3 Lamps, the lens of which are used for different types of headlamps and which may be reciprocally incorporated or grouped with other lamps: The provisions laid down in 4.3.2 above are applicable.
- 4.3.3.1. In addition, where the same lens is used, the latter may bear the different approval marks relating to the different types of headlamps or units of lamps, provided that the main body of the headlamp, even if it cannot be separated from the lens, also comprises the space described in 3.2 above and bears the approval marks of the actual functions. If different types of headlamps comprise the same main body, the latter may bear the different approval marks.
- 4.3.3.2 Annex 2, figure 14 of ECE R113, (Supplement **5** to **01 series of amendments** of the regulation) may be used as examples of arrangements of approval marks relating to the above case.
- 4.4 On the prototype for type approval, the markings may be provided by suitable

temporary methods and need not necessary be obtained from the tools used for series production.

5 GENERAL SPECIFICATIONS

5.1 Each sample shall conform to the specifications set forth in 6 to 8 below.

5.2 Headlamps shall be so made as to retain their prescribed photometric characteristics and to remain in good working order when in normal use, in spite of the vibrations to which they may be subjected.

Note : Requirements of 5.2 above are deemed to be satisfied, if requirements specified in this standard are complied with.

5.2.1. Headlamps shall be fitted with a device enabling them to be so adjusted on the vehicles as to comply with the rules applicable to them. Such a device may or may not provide horizontal adjustment, provided that the headlamps are so designed that they can maintain a proper horizontal aiming even after the vertical aiming adjustment. Such a device need not be fitted on units in which the reflector and the diffusing lens cannot be separated, provided the use of such units is confined to vehicles on which the headlamp setting can be adjusted by other means. Where a headlamp providing a passing beam and a headlamp providing a driving beam, each equipped with its own filament lamp(s) or gas-discharge light source or LED module(s), are assembled to form a composite unit the adjusting device shall enable each optical system individually to be duly adjusted.

5.2.2 However, these provisions (5.2.1.) shall not apply to headlamp assemblies whose reflectors are indivisible. For this type of assembly the requirements of 6.3 of this standard apply.

5.3 For Class A or B or C or D

5.3.1 **Headlamps shall be equipped with filament lamp(s) approved according to AIS 034 (Part 1) (Rev.2) standard and/or, with (an) LED module(s). In the case of the use of additional light source(s) and/or additional lighting unit(s) to provide bend lighting, only categories of filament lamps covered by AIS 034 (Part 1) (Rev. 2) standard, provided that no restriction on the use for bending light is made in AIS 034 (Part 1) (Rev.2) standard , and/or LED modules(s) shall be used.**

5.3.2. **It is possible to use two filament light sources for the principal passing beam and several filament light sources for the driving beam. Any AIS 034 (Part 1) (Rev.2) filament lamp may be used, provided that:**

(a) No restriction on the use is made in AIS 034 (Part 1) (Rev.2) ;

(b) For Class A and B, its reference luminous flux at 13.2V for principal dipped-beam does not exceed 900 lm;

(c) For Class C and D, its reference luminous flux at 13.2V for principal dipped-beam does not exceed 2,000 lm.

The design of the device shall be such that the filament lamp can be fixed in no other position but the correct one.

Note: A headlamp is regarded as satisfying the requirements of this paragraph if the filament lamp can be easily fitted into the headlamp and the positioning lugs can be correctly fitted into their slots even in darkness

The filament lamp holder shall conform to the characteristics given in IEC Publication 60061. The holder data sheet relevant to the category of filament lamp used, applies.

Note: Conditions of 5.3.3 are to be verified by using appropriate gauge or a standard reference filament lamp.

5.3.3 For lamps equipped with (an) LED module(s):

5.3.3.1. The electronic light source control gear(s), if applicable, shall be considered as being part of the headlamp; they may also be part of the LED module

5.3.3.2. The headlamp and the LED module(s) themselves shall comply with the relevant requirements specified in Annex M of this Standard. The compliance with the requirements shall be tested.

5.3.3.3. The total objective luminous flux of all LED modules producing the principal passing beam shall be measured as described in paragraph 5. Of Annex M. The following minimum and maximum limits shall apply:

	Headlamps Class A	Headlamps Class B	Headlamps Class C	Headlamps Class D
Principal passing-beam minimum	150 lumens	350 lumens	500 lumens	1,000 lumens
Principal passing-beam maximum	900 lumens	1,000 lumens	2,000 lumens	2,000 lumens

5.3.3.4. In the case of replaceable LED module, the removal and replacement of this LED module, as described in Annex M, paragraph 1.4.1., shall be demonstrated to the satisfaction of the technical service.

5.4 CLASS E HEADLAMPS

5.4.1. The headlamp shall be equipped with gas-discharge light source(s) approved according to AIS-034 (Part 2)(Rev. 2) **and/or (an) LED module(s).**

In the case of the use of additional light source(s) and/or additional lighting unit(s) to provide bend lighting, only categories of filament lamps covered by AIS-034 (Part 1)(Rev. 2), provided that no restriction on the use for bending light is made in AIS-034 (Part 2)(Rev. 2), and / or LED

modules(s) shall be used.

- 5.4.2. In the case of replaceable gas-discharge light sources the lamp holder shall conform to the dimensional characteristics as given on the data sheet of IEC Publication 60061-2, relevant to the category of gas-discharge light source used. The gas-discharge light source shall fit easily into the headlamp.

Note: Conditions of **5.4.2** are to be verified by using appropriate gauge or a standard reference gas discharge light source.

5.4.3. In the case of (an) LED module(s) the following requirements apply:

5.4.3.1. The electronic light source control gear(s), if applicable, shall be considered as being part of the headlamp; they may also be part of the LED module (s);

5.4.3.2. The headlamp and the LED module(s) themselves shall comply with the relevant requirements specified in Annex 12 M of this Standard.. The compliance with the requirements shall be tested.

5.4.3.3. The total objective luminous flux of all LED modules producing the principal passing beam shall be measured as described in paragraph 5. of Annex M. The following minimum limit shall apply:

	Headlamps Class E
Passing beam minimum	2 000 lumen

- 5.5 In addition, Class B or C or D or E headlamps shall be complementary tested according to the requirements of Annex D to ensure that in use there is no excessive change in photometric performance.

- 5.6 If the lens of Class B or C or D or E headlamp is of plastic material, tests shall be done according to the requirements of Annex F.

- 5.7. On headlamps designed to provide alternately a driving beam and a passing beam, **or headlamp systems including additional light source(s) and/or additional lighting unit(s) used to produce bend lighting**, any mechanical, electromechanical or other device incorporated in the headlamp for these purposes shall be so constructed that:

- 5.7.1. The device is strong enough to withstand 50,000 operations; **under normal conditions of use. In order to verify compliance with this requirement, the test agency may:**

(a) Require the applicant to supply the equipment necessary to perform the test;

(b) Forego the test if the headlamp presented by the applicant is accompanied by a test report, issued by a test agency responsible for approval tests for headlamps of the same construction (assembly), confirming compliance with this requirement.

- 5.7.2. **Except for additional light source(s) and additional lighting unit(s) used to produce bend lighting**, in the case of failure it shall be possible to obtain automatically a passing beam or a state with respect to the photometric conditions which yields values not exceeding 1200 cd in Zone 1 and at least 2400 cd at 0,86D-V by such means as e.g. switching off, dimming, aiming downwards, and/or functional substitution;
- 5.7.3. **Except for additional light source(s) and additional lighting unit(s) used to produce bend lighting**, either the passing beam or the driving beam shall always be obtained without any possibility of the mechanism stopping in between the two positions;
- 5.7.4 The user cannot, with ordinary tools, change the shape or position of the moving parts.
- 5.8 For Class E, the headlamp and ballast system shall not generate radiated or power line disturbances to cause a malfunction of other electric/electronic systems of the vehicle. (See Note below)
- Note: Compliance with the requirements for electromagnetic compatibility is relevant to the individual vehicle type. Verification of this requirement shall be as per relevant part of AIS-004 (Part 3) as and when implemented.
- 5.9 **The definitions in paragraphs 2.7.1.1.3. and 2.7.1.1.7., in AIS 008 (Rev. 1) standard allow the use of LED module, which may contain holders for other light sources. Notwithstanding this provision a mixture of LED'(s) and other light sources for the passing beam or each driving beam, as specified by this Standard is not allowed.**
- 5.10. **A LED module shall be:**
- (a) **Only removable from its device with the use of tools, unless it is stated in the communication sheet that the LED module is non-replaceable and;**
 - (b) **So designed that regardless of the use of tool(s), it is not mechanically interchangeable with any replaceable approved light source.**

6. ILLUMINATION

6.1 General provisions

- 6.1.1 Headlamps shall be so made that they give adequate illumination without dazzle when emitting the passing beam, and good illumination when emitting the driving beam.

Note: Requirements of 6.1.1 above are deemed to be satisfied, if requirements specified in this standard are complied with.

- 6.1.2. The luminous intensity produced by the headlamp shall be measured at 25 m distance by means of **a photoelectric cell having a useful area comprised within a square of 65 mm side. The point HV is the centre-point of the coordinate system with a vertical polar axis. Line h is the horizontal**

through HV (see Annex C of this Standard).

6.1.3. For Class A or B or C or D

6.1.3.1. **Apart from (an) LED module(s), the headlamps shall be checked by means of an uncoloured standard (étalon) filament lamp designed for a rated voltage of 12 V. During the checking of the headlamp, the voltage at the terminals of the filament lamp shall be regulated so as to obtain the reference luminous flux at 13.2 V as indicated at the relevant data sheet of AIS-034 (Part 2)(Rev.2) In order to protect the standard (étalon) filament lamp during the process of photometric measurement it is permissible to carry out the measurements at a luminous flux that differs from the reference luminous flux at 13.2 V. If the test laboratory chooses to carry out measurements in such a manner the luminous intensity shall be corrected by multiplying the measured value by the individual factor F lamp of the standard (étalon) filament lamp in order to verify the compliance with the photometric requirements where:**

$F \text{ lamp} = \Phi \text{ reference} / \Phi \text{ test}$

$\Phi \text{ reference}$ is the reference luminous flux at 13,2 V as specified in the relevant data sheet of AIS-034 (Part 1)(Rev. 2)

$\Phi \text{ test}$ is the actual luminous flux used for the measurement.

6.1.3.2 Depending on the number of filament lamps for which the headlamp is designed, it shall be considered acceptable if it meets the requirements of 6 with the same number of standard (étalon) filament lamp(s), which may be submitted with the headlamp.

6.1.3.3. LED module(s) shall be measured at 6.3 V or 13.2 V respectively, if not otherwise specified within this Standard. LED module(s) operated by an electronic light source control gear, shall be measured as specified by the applicant.

6.1.4. For Class E with (a) gas-discharge light source(s) according to AIS 034 (Part 2) (Rev 2).

6.1.4.1. The headlamp shall be deemed satisfactory if the photometric requirements set in the **present paragraph 6** are met with one light source, which has been aged during at least 15 cycles, in accordance with D-4 of Annex D of AIS-034 (Part 2)(Rev. 2).

Where the gas-discharge light source is approved according to AIS-034 (Part 2)(Rev. 2). it shall be a standard (étalon) light-source and its luminous flux may differ from the objective luminous flux specified in AIS-034 (Part 2)(Rev. 2). In this case, the illuminances shall be corrected accordingly.

The above correction does not apply to distributed lighting systems using a non-replaceable gas-discharge light source or to headlamps with the ballast(s) totally or partially integrated. Where the gas-discharge light source is not approved according to AIS-034 (Part 2)(Rev. 2), it shall be a production non-replaceable light source.

The voltage applied to the terminals of the ballast(s) is: either: 13.2 V 0.1 V for 12 V systems or: as otherwise specified (see Annex L).

- 6.1.4.2. The dimensions determining the position of the arc inside the standard gas-discharge light source are shown in the relevant data sheet of AIS-034 (Part 2) (Rev. 2).
- 6.1.4.3. **Four seconds after ignition of a headlamp which has not been operated for 30 minutes or more, at least 37,500 cd shall be reached at point HV of a driving beam and 3,750 cd at point 2 (0.86D-V) of a passing beam for headlamps incorporating driving beam and passing beam functions, or 3,750 cd at point 2 (0.86D-V) for headlamps having only a passing beam function. The power supply shall be sufficient to secure the quick rise of the high current pulse.**
- 6.1.5. **For Class E with (an) LED module(s)**
 - 6.1.5.1. **LED module(s) shall be measured at 6.3 V or 13.2 V respectively, if not otherwise specified within this Standard. LED module(s) operated by an electronic light source control gear, shall be measured as specified by the applicant.**
 - 6.1.6. **In the case of headlamp systems having additional light source(s) and/or additional lighting unit(s) used to produce bend lighting, the additional light source(s) shall be measured according to the paragraph 6.1.3., 6.1.4. and 6.1.5.**
- 6.2. Provisions concerning passing beams
 - 6.2.1. For a correct aiming the principal passing beam shall produce a sufficiently sharp "cut-off" to permit a satisfactory visual adjustment with its aid as indicated in paragraph 6.2.2 below. **The aiming shall be carried out using a flat vertical screen set up at a distance of 10 or 25 m forward of the headlamp and at right angles to the H-V. The screen shall be sufficiently wide to allow examination and adjustment** of the "cut-off" of the passing beam over at least 3° on either side of the V-V line. The "cut-off" shall be substantially horizontal and shall be as straight as possible from at least 3° L to 3° R. In case the visual aim leads to problems or ambiguous positions, the instrumental method as specified in Annex J, J-2 and J-4., shall be applied and the quality or rather the sharpness of the "cut-off" and the linearity shall be checked on performance.
 - 6.2.2. The **Principal passing beam** shall be aimed so that:
 - 6.2.2.1 For horizontal adjustment: The beam is as symmetrical as possible with reference to line V-V.
 - 6.2.2.2. For vertical adjustment: The horizontal part of the "cut-off" line is adjusted to its nominal position (**0.57 degree**) below the H-H-line. If, however, vertical adjustment cannot be performed repeatedly to the required position within the allowed tolerances, the instrumental method of Annex J, J-4 and J-5. shall be

applied to test compliance with the required minimum quality of the "cut-off" line and to perform the beam vertical adjustment.

6.2.3 When so aimed, the headlamp needs, if its approval is sought solely for provision of a passing beam (see **6.2.3.1**) to comply with the requirements set out in **6.2.5** to **6.2.7.1** below if it is intended to provide both a passing beam and a driving beam, it shall comply with the requirements set out in **6.2.5**, **6.2.6** and **6.3**.

6.2.4. Where a headlamp so aimed does not meet the requirements set out in paragraphs **6.2.5**, **6.2.6**. and **6.3**., its alignment may be changed, except for headlamps that have no mechanism to adjust horizontal aim, on condition that the axis of the beam is not displaced laterally by more than **0.5 degree to the right or left and vertically by not more than 0.25 degree up or down**. To facilitate alignment by means of the "cut-off", the headlamp may be partially occulted in order to sharpen the "cut-off". However, the "cut-off" should not extend beyond the line H-H.

6.2.5. **The passing beam shall meet the requirements as shown in the applicable table below and the applicable figure as shown in Annex 3-C.**

Notes:

For Class E headlamps the voltage applied to the terminals of the ballast(s) is either 13.2 V 0.1 V for 12 V systems or as otherwise specified (see Annex 4 L).

"D" means under the H-H line.

"U" means above the H-H line

"R" means right of the V-V line.

"L" means left of the V-V line.

6.2.5.1 For Class A headlamps (**Figure B in Annex C**):

Test point/ line/ zone	Angular coordinates - degrees*		Required luminous intensity in cd
Any point in Zone 1	0° to 15°U	5°L to 5°R	≤320 cd
Any point on line 25L to 25R	1.72°D	5°L to 5°R	≥ 1,100 cd
Any point on line 12.5L to 12.5R	3.43°D	5°L to 5°R	≥ 550 cd

6.2.5.2 For Class B headlamps (**Figure C in Annex C**):

Test point/ line/ zone	Angular coordinates - degrees*	Required luminous

			intensity in cd
Any point in Zone 1	0° to 15°U	5°L to 5°R	≤700 cd
Any point on line 50L to 50R except 50V	0.86°D	2.5°L to 2.5°R	≥ 1,100 cd
Point 50V	0.86°D	0	≥ 2,200cd
Any point on line 25L to 25R	1.72°D	5°L to 5°R	≥ 2,200cd
Any point in Zone 2	0.86°D to 1.72°D	5°L to 5°R	≥ 1,100 cd

6.2.5.3 **For Class C, D or E headlamps. (Figure D in Annex C):**

Test point / line / zone	Test point Angular coordinates degrees*		Required luminous intensity in cd			
			Minimum			Maximum
			Class C	Class D	Class E	Class C,D,E
1	0.86°D	3.5°R	2,000	2,000	2,500	13,750
2	0.86°D	0	2,450	4,900	4,900	--
3	0.86°D	3.5°L	2,000	2,000	2,500	13,750
4	0.50°U	1.50°L and 1.50°R	--	--	--	900
5	2.00°D	15°L and 15°R	550	1,100	1,100	--
6	4.00°D	20°L and 20°R	150	300	600	--
7	0	0	--	--	--	1,700
Line 1	2.00°D	9°L to 9°R	1,350	1,350	1,900	--
8**	4.00°U	8.0°L	**			700
9**	4.00°U	0	∑ 8+ 9 +10 ‡ 150 cd			700
10**	4.00°U	8.0°R	**			700
11**	2.00°U	4.0°L	∑ 11+ 12 + 13 ‡ 300 cd			900
12**	2.00°U	0	**			900
13**	2.00°U	4.0°R	**			900
14**	0	8.0°L and 8.0°R	50 cd**	50 cd**	50 cd**	--
15**	0	4.0°L and 4.0°R	100 cd**	100 c	100 c	900
Zone 1	1°U/8°L-4°U/8°L-4°U/8°R-1°U/8°R-0/4°R-0/1°R-0.6°U/0-		--	--	--	900

	0/1°L-0/4°L- 1°U/8°L					
Zone 2	>4U to <15 U	8°L to 8°R	--	--	--	700

* 0.25 tolerance allowed independently at each test point for photometry unless indicated otherwise

** On request of the applicant during measurement of these points, the front position lamp approved to AIS 10 (Part 3) (Rev.1); if combined, grouped, or reciprocally incorporated shall be switched ON.

Other general text: UN ECE type approval at reference luminous flux according to AIS 034 (Part 1) (Rev 2). Nominal aim for photometry:

Vertical: 1 per cent D (0.57°D) Horizontal: 0°

Allowed tolerances for photometry:

Vertical: 0.3°D to 0.8°D Horizontal: ± 0.5°D L-R

6.2.6. The light shall be as evenly distributed as possible within zones 1, and 2 for Class C, D or E headlamps.

6.2.6.1. However, the additional light source(s) or additional lighting unit(s) shall not be activated when the bank angle is less than 3 degrees.

6.2.7 Either one or two filament light sources (Classes A, B, C, D) or one gas discharge light source (class E) or one or more LED module(s) (Classes C, D, E) are permitted for the principal passing beam.

6.2.8. Additional light source(s) and/or additional lighting unit(s) used to produce bend lighting is (are) permitted, provided that:

6.2.8.1. The following requirement regarding illumination shall be met, when the principal passing beam(s) and corresponding additional light source(s) used to produce bend lighting are activated simultaneously:

(a) Left bank (when the motorcycle is rotated to the left about its longitudinal axis) the luminous intensity values shall not exceed 900cd in the zone extending from HH to 15 deg above HH and from VV to 10 degrees left.

(b) Right bank (when the motorcycle is rotated to the right about its longitudinal axis) the luminous intensity values shall not exceed 900cd in the zone extending from HH to 15 deg above HH and from VV to 10 degrees right.

6.2.8.2. This test shall be carried out with the minimum bank angle specified by the applicant simulating the condition by means of the test fixture etc

6.2.8.3. For this measurement, at the request of the applicant, principal passing beam and additional light source(s) used to produce bend lighting, may be measured individually and the photometric values obtained combined to

determine compliance with the specified luminous intensity values.

6.3 Provisions concerning driving beams

6.3.1 In the case of a headlamp designed to provide a driving beam and a passing beam, measurements of the luminous intensity of the driving beam shall be taken with the same headlamp alignment as applied to the condition of paragraph **6.2.** above; in the case of a headlamp providing a driving beam only, it shall be so adjusted that the area of maximum **luminous intensity (IM)** is centred on the point of intersection of lines H-H and V-V; such a headlamp need only meet the requirements referred to in paragraph **6.3.**

6.3.2. Irrespective of the type of light source (LED module(s) or filament light source(s) or gas discharge light source) used to produce the passing beam, several light sources either:

- (a) one or more filament light sources listed in AIS 034 (Part1) (Rev.2) standard (Classes A, B, C, D); or**
- (b) Gas discharge light sources listed in AIS 034 (Part 2) (Rev.2) standard (Class E); or**
- (c) LED module(s) (Classes C, D, E) may be used for each individual driving beam.**

6.3.3. Except for Class A headlamps the luminous intensity produced by the driving beam shall either conform to the requirements of paragraph 6.3.3.1. (Primary Driving Beam) or paragraph 6.3.3.2. (Secondary Driving Beam).

A Primary Driving Beam according to the requirements of paragraph 6.3.3.1 can be approved in any case.

A Secondary Driving beam according to the requirements of paragraph 6.3.3.2. can only be approved in the case where the driving beam is operated together with a passing beam or a primary driving beam.

6.3.3.1. The luminous intensity of a Primary Driving Beam shall conform to the following table (Figure E in Annex C):

Test point number	Test point angular coordinates - degrees*	Required luminous intensity [cd]					
		Class B		Class C		Class D, E	
		MIN	MAX	MIN	MAX	MIN	MAX
1	H-V	16,000	---	20,000	---	30,000	---
2	H-2.5°R and 2.5°L	9,000	---	10,000	---	20,000	---
3	H-5°R and 5°L	2,500	---	3,500	---	5,000	---
4	H-9°R and 9°L	---	---	2000	---	3,400	---
5	H-12°R and 12°L	---	---	600	---	1,000	---
6	2°U-V	---	---	1000	---	1,700	---

	MIN luminous intensity of the maximum (IM)	20,000	---	25,000	---	40,000	---
	MAX luminous intensity of the maximum (IM)	---	215,000	---	215,000	---	215,000
* 0.25° tolerance allowed independently at each test point for photometry unless indicated otherwise.							

6.3.3.2. The luminous intensity of a Secondary Driving Beam shall conform to the following table (Figure F in Annex C):

Test point number	Test point angular coordinates - degrees *	Required luminous intensity [cd]					
		Class B		Class C		Classes D, E	
		MIN	MAX	MIN	MAX	MIN	MAX
1	H-V	16,000	---	20,000	---	30,000	---
2	H-2.5°R and 2.5°L	9,000	---	10,000	---	20,000	---
3	H-5°R and 5°L	2,500	---	3,500	---	5,000	---
6	2°U-V	---	---	1,000	---	1,700	---
	MIN luminous intensity of the maximum (I _M)	20,000	---	25,000	---	40,000	---
	MAX luminous intensity of the maximum (I _M)	---	215,000	---	215,000	---	215,000
* 0.25° tolerance allowed independently at each test point for photometry unless indicated otherwise.							

6.3.4. The reference mark (I'M) of the maximum luminous intensity (IM), referred to in paragraphs 4.2.2.6. and 6.3.3.1. or 6.3.3.2. shall be obtained by the ratio:

$$I'M = IM/4300$$

This value shall be rounded off to the value 7.5 -10 -12.5 -17.5 -20 - 25 - 27.5 -30 -37.5 -40 -45 -50.

6.4 In the case of headlamps with an adjustable reflector, additional tests shall be made after the reflector has been moved vertically ± 2 degrees or at least into the maximum position, if less than 2 degrees, from its initial position by means of the headlamp adjusting device. The whole headlamp shall then be re-positioned (for example by means of the goniometer) by moving it through the same number of degrees in the opposite direction to the movement of the reflector. The following measurements shall be made and the points shall be within the required limits: passing beam: points HV and 0.86D-V driving beam: IM and point HV (percentage of IM).

6.5 The screen illumination values mentioned in 6.2 and 6.3 above shall be measured by means of a photoreceptor, the effective area of which shall be

contained within a square of 65 mm side.

7. COLOUR

- 7.1 The colour of the light emitted shall be white. (Refer AIS-010 (Part 5)(Rev. 2) for chromaticity coordinates

8. EXTENSION OF TYPE APPROVAL

- 8.1 Details given in 9.0 of part 1 of this standard are applicable to this part also.

[Cross reference of this clause to be reviewed after part 1 revision is prepared and finalized as per ECE R 112.]

8.1.1 Reserved

8.1.2 Reserved

8.2. Reserved

8.3. Reserved

9 CONFORMITY OF PRODUCTION

The conformity of production procedures shall comply with those set out in the AIS-037 with the following requirements:

- 9.1. Headlamps approved under this standard shall be so manufactured as to conform to the type approved by meeting the requirements set forth in 6 and 7.
- 9.2. the minimum requirements for conformity of production control procedures set fourth in Annex E to this standard shall be complied with.
- 9.3. The minimum requirements for sampling by testing agency set forth in Annex G to this standard shall be complied with.
- 9.4. The normal frequency of these verifications shall be once every two years.
- 9.5. Headlamps with apparent defects are disregarded.
- 9.6. The reference mark is disregarded.

10 PENALTIES FOR NON-CONFORMITY OF PRODUCTION

- 10.1. Penalties for non-conformity of production shall be as prescribed in AIS-037.

11 Reserved.

12 Reserved.

13 TRANSITIONAL PROVISION

[Transitional provision clauses to be reviewed based on notification status for

AIS 10 (Part 2) Rev. 1 standard.]

- 13.1 At the request of the applicant, type approvals for compliance to headlamp of class A or class B of AIS-010(Part 2) (Rev.1):2010, shall be granted by testing agencies from (dd/mm/yy) (date of adoption in CMVR-TSC). Such type approvals shall be deemed to be compliance to headlamp covered under Annex D or Annex E of AIS-010:2004.
- ~~13.2~~ At the request of applicant, type approval to the compliance to Annex D or Annex E of AIS-010:2004 shall be granted up to the notified date of implementation of AIS-010 (Part 2) (Rev.1):2010.
- 13.3 Type approvals issued for compliance to Annex D or Annex E of AIS-010 : 2004 shall be extended to approval of Class A or Class B of AIS-010 (Part 2) (Rev.1):2010 subject to satisfactory compliance of the following:
- 13.3.1 Marking as per 3.0 and sub-clauses for 4.0 applicable for marking.
- 13.3.2 In case of “E/e” approved devices, requirements specified in 14.
- 13.3.3 In case of type approved headlamps as per Annex D of AIS-010:2004, Photometric requirements as per 6.2.5.1.
- Note: Additional verification for the above need not be carried out, if compliance to the above requirements has already been established during the type approval as per Annex D or Annex E of AIS-010:2004.
- 13.4 Extension of Approvals for engineering and administrative changes:
- 13.4.1 In the case of 13.1, extensions shall be granted subject to the conditions of AIS-010 (Part 2) (Rev.1):2010. Such extensions shall be deemed to be compliance to AIS-010:2004.
- 13.4.2 In the case of 13.2, extensions shall be granted subject to conditions of AIS-010:2004 till the notified date of implementation of AIS-010 (Part 2) (Rev.1):2010.
- 13.5 Type approvals for compliance to AIS-037, already been granted, shall continue to be valid for AIS-010 (Part 2) (Rev.1):2010.

14 ESTABLISHING COMPLIANCE OF E/e APPROVED HEADLAMPS TO THIS STANDARDS

- 14.1 As an exception to 7.4 of AIS-037, (or related administrative decisions) for certifying compliance of “E”/”e” approved headlamps to this standard, the test for the following shall be carried out by testing agency
- 14.1.1 Provision concerning passing beam. (6.2 of this standard)
- 14.1.2 Provision concerning driving beam. (6.3 of this standard)

14.1.3 In the case of 14.1.1 and 14.1.2 above, no measured value deviates unfavourably by more than 20 per cent from the value prescribed in this standard. For values B 50 R and zone III, the maximum unfavourable deviation may be respectively:

14.1.3.1 Class A headlamp: No measured value deviates unfavourably by more than 20 per cent from the value prescribed in this standard.

[Clauses to be reviewed.]

14.1.3.2 Class B, C and D headlamp

No measured value deviates unfavourably by more than 20 per cent from the value prescribed in this standard. For values in zone III for class B headlamp, Zone 1 for Class C and D headlamp, the maximum unfavourable deviation may be respectively:

0.3 lux equivalent 20 per cent 0.45 lux equivalent 30 per cent

[Clauses to be reviewed.]

14.1.3.3 For Class E headlamp:

No measured value deviates unfavourably by more than 20 per cent from the value prescribed in this standard. For values in zone 1, the maximum unfavourable deviation may be respectively:

0.3 lux equivalent 20 per cent

0.45 lux equivalent 30 per cent

[Clauses to be reviewed.]

14.1.4 Tests for stability of photometric performance of headlamps in operation D-2.2 and Annex D of this standard.

15 AMENDMENTS TO ECE REGULATIONS AFTER THE LEVEL DESCRIBED IN 0.3 OF FOREWORD

15.1 Supplements

In case of changes in ECE regulation, which are issued as supplements (Supplements do not affect the earlier type approvals) at the request of applicant, approval of compliance to this standard shall be issued taking into account the changes arising out of such supplement(s) to ECE regulation with approval from Chairman AISC. This shall be incorporated in the test report.

Note : Such changes will be considered for inclusion in this standard at the time of its next amendment /revision.

15.2 Series of amendments

Changes in ECE regulation, which are issued as series of amendments (series of amendments may affect the earlier type approvals) will not be considered for issuing approval to this standard.

However, Chairman, AISC may, on a case to case basis, permit to accept latest series of amendments.

This shall be incorporated in the test report.

Note : Such changes will be considered for inclusion in this standard at the time of its next revision.

ANNEX A

(See 2.1)

INFORMATION AND SAMPLES TO BE SUBMITTED AT THE TIME OF APPLICATION FOR TYPE APPROVAL

- A-1. Trade name or mark of the device:
- A-2. Manufacturer's name for the type of device:
- A-3. Manufacturer's name and address:
 - A-3.1 Telephone No
 - A-3.2 FAX. No.
 - A-3.3 E mail address
 - A-3.4 Contact person
- A-4. If applicable, name and address of manufacturer's representative:
- A-5 whether the headlamp is intended to provide both a passing beam and a driving beam or only one of these beams;
- A-6 Whether it concerns a Class A or B or C or D or E headlamp;
- A-7 The category of the filament lamp(s) used, as listed in AIS-034 (Part 1)(Rev. 1) and its amendments in force at the time of application for type approval, if any.
- A-8 The category of gas-discharge light source as listed in AIS-034 (Part 2)(Rev. 1) if any.
- A-9 For LED modules, the light source module specific identification code(s), if any.**
- A-10 For additional lighting unit(s), the additional lighting unit identification code(s), if any**
- A- 11 Drawings in triplicate in sufficient detail to permit identification of the type and representing a frontal view of the headlamp, with details of lens ribbing if any, and the cross-section; the drawings shall indicate the space reserved for the approval mark; **and, if applicable,**
 - (a) In the case of LED module(s), the drawings shall indicate the space(s)**

reserved for the specific identification code(s) of the module(s)

(b) In the case of additional lighting unit(s), the space(s) reserved for the specific identification code(s) on the additional lighting unit(s) and the headlamp(s) producing the principal passing beam;

(c) In the case of additional lighting unit(s), the geometrical conditions of installation of the device(s) that meet the requirements of paragraph 6.2.8.

A-12 A brief technical description, if any, including;

A-13 For gas discharge lamps, the make and type of the ballast(s) in the case that the ballast(s) is (are) not integrated with the light source(s);

A-14 In the case of LED module(s),

(a) A brief technical specification of the LED module(s);

(b) A drawing with dimensions and the basic electrical and photometric values and the objective luminous flux and for each LED module a statement whether it is replaceable or not;

(c) In case of electronic light source control gear, information on the electrical interface necessary for approval testing;

A-15 In the case of a headlamp designed to provide bend lighting, the minimum bank angle(s) to satisfy the requirement of paragraph 6.2.8.1.

ANNEX C

Spherical Coordinate Measuring System and Test Point Locations

Figure A

Spherical Coordinate Measuring System

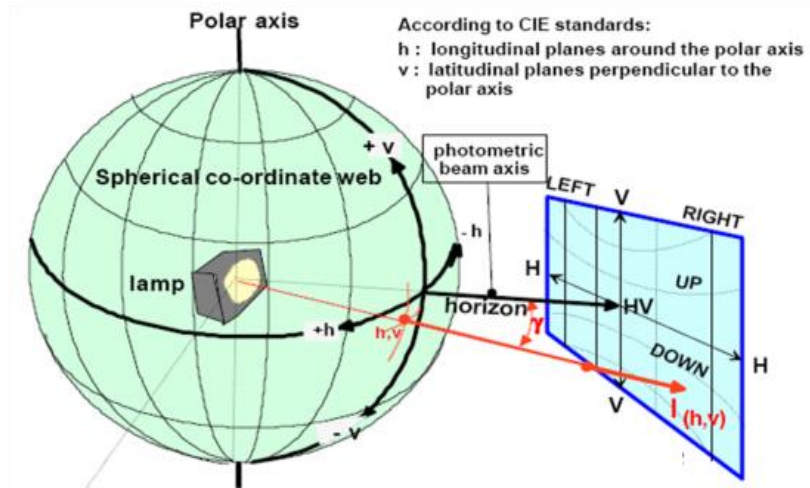

$$E_{25m} = I(h,v) \times \cos^2 \theta$$

The angular co-ordinates are specified in degrees on a sphere with a vertical polar axis according to CIE publication No. 70-1987 "The measurement of absolute luminous intensity distributions", i.e. corresponding to a goniometer with a horizontal ("elevation") axis fixed to the ground and a second, moveable ("rotation") axis perpendicular to the fixed horizontal axis.

Figure B

Passing beam -test points and Zones for Class A headlamp(s):

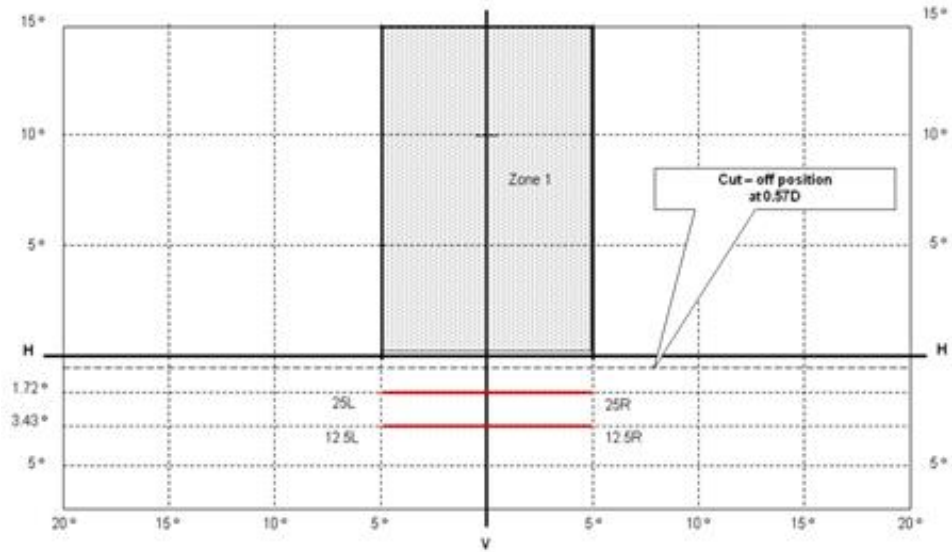

H-H: horizontal plane passing through

V-V: vertical plane focus of headlamp

Figure C

Passing beam test points and Zones for Class B headlamp(s):

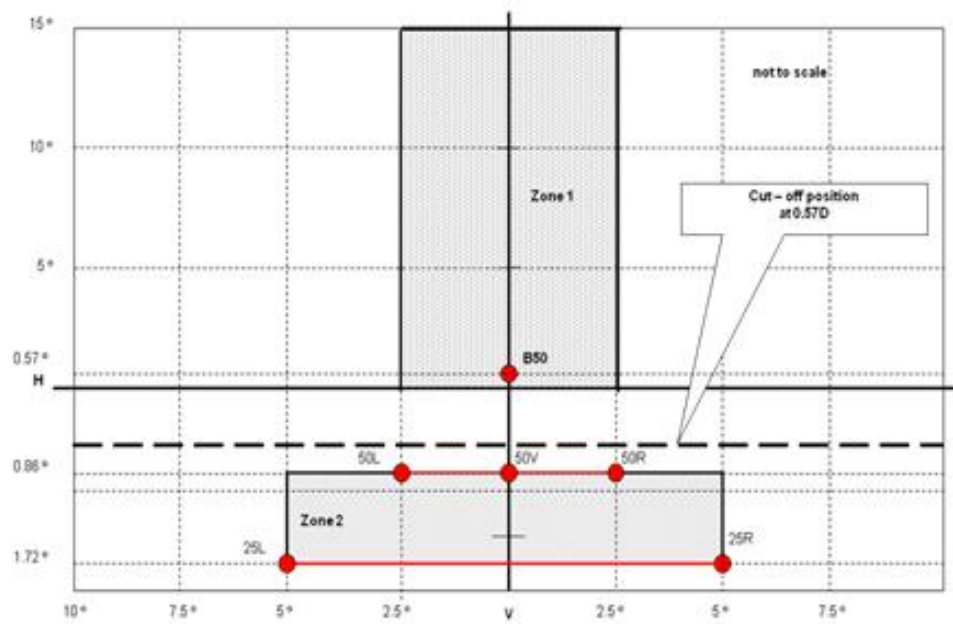

H-H: horizontal plane passing through

V-V: vertical plane focus of headlamp

Figure D

Passing beam -position of test points and zones for Classes C, D and E headlamp(s):

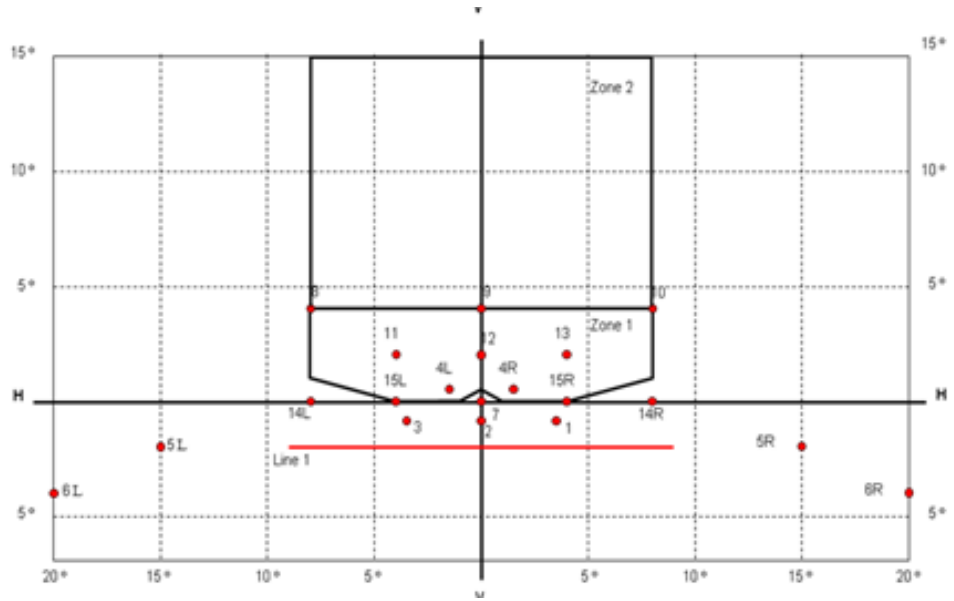

Figure E
Primary Driving Beam -position of test points

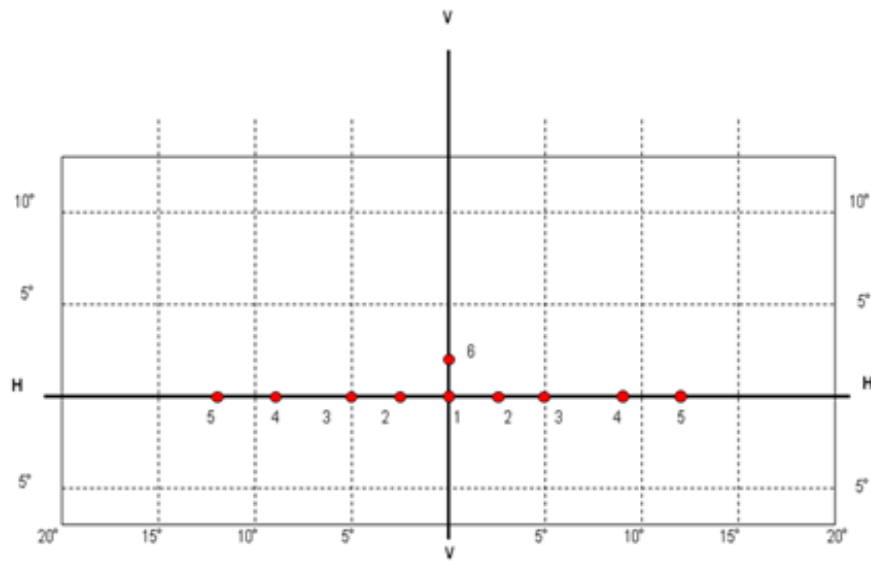
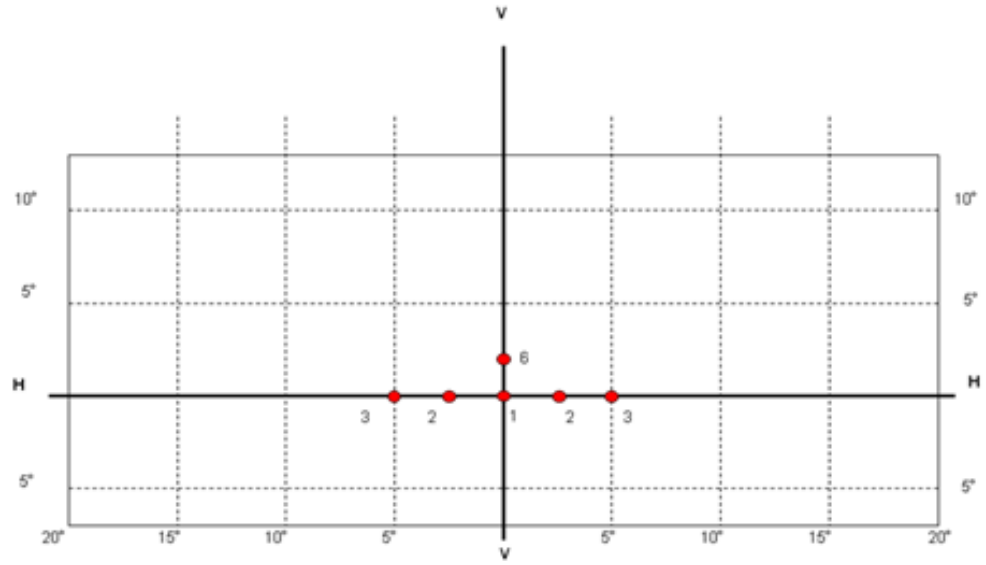

Figure F
Secondary Driving Beam -position of test points



ANNEX D

(See 5.5)

TESTS FOR STABILITY OF PHOTOMETRIC PERFORMANCE OF HEADLAMPS IN OPERATION - TESTS ON COMPLETE CLASS B, C, D AND E HEADLAMPS

Once the photometric values have been measured according to the prescriptions of this **standard**, in the point for I_{max} for driving-beam and in points 0.50U/1.5L and 0.50U/1.5R, 50R, 50L for Class B passing-beam and in points 0.86D-3.5R, 0.86D-3.5L, 0.50U-1.5L and 0.50U-1.5R for Classes C, D and E, for passing-beam a complete headlamp sample shall be tested for stability of photometric performance in operation. "Complete headlamp" shall be understood to mean the complete lamp itself, including those surrounding body parts, filament lamps, gas discharge light sources **or LED module(s)** which could influence its thermal dissipation.

The tests shall be carried out:

(a) in a dry and still atmosphere at an ambient temperature of $23\text{ }^{\circ}\text{C} \pm 5^{\circ}\text{C}$, the test sample being mounted on a base representing the correct installation on the vehicle;

(b) in case of replaceable light sources: using mass production filament light sources, which have been aged for at least one hour, or mass production gas-discharge light sources, which have been aged for at least 15 hours or mass production LED modules which have been aged for at least 48 hours and cooled down to ambient temperature before starting the tests as specified in this standard. The LED modules supplied by the applicant shall be used. The measuring equipment shall be equivalent to that used during headlamp type approval tests.

The test sample shall be operated without being dismantled from or readjusted in relation to its test fixture. The light source used shall be a light source of the category specified for that headlamp.

D-1.1 Clean headlamp

The headlamp shall be operated for 12 hours as described in D-1.1.1 and checked as prescribed in D-1.1.2.

D-1.1.1. Test Procedure:

The headlamp shall be operated for a period according to the specified time, so that:

(a) In the case where only one lighting function driving or passing beam or front fog lamp is to be approved, the corresponding light source is lit for the prescribed time. (See note below)

Note : When the tested headlamp includes signaling lamps, the latter shall be lit for the duration of the test. In the case of a direction indicator lamp, it shall be lit in flashing mode with an on/off time of approximately one to one.

(b) In the case of a headlamp with a passing beam and one or more driving beams or in case of a headlamp with a passing beam and a front fog lamp:

(i) the headlamp shall be subjected to the following cycle until the time specified is reached:

- 15 minutes, passing-beam filament lit;
- 5 minutes, all functions lit.

(ii) if the applicant declares that the headlamp is to be used with only the passing beam lit or only the driving beam(s) lit {See note below} at a time, the test shall be carried out in accordance with this condition, activating {See note under D-1.1.1.1 (a)} successively the passing beam half of the time and the driving beam(s) (simultaneously) for half the time specified in D-1.1 above

Note : Should two or more lamp light source be simultaneously lit when headlamp flashing is used, this shall not be considered as being normal use of the light source simultaneously.

(c) in the case of a headlamp with a front fog lamp and one or more driving beams:

(i) the headlamp shall be subjected to the following cycle until the time specified is reached:

- 15 minutes, front fog lamp lit;
- 5 minutes, all functions lit.

(ii) if the applicant declares that the headlamp is to be used with only the front fog lamp lit or only the driving beam(s) lit {See note under D-1.1.1.1 (b)} at a time, the test shall be carried out in accordance with this condition, activating {See note under

D-1.1.1.1 (a)} below) successively the front fog lamp half of the time and the driving beam(s) (simultaneously) for half the time specified in D-1.1 above.

(d) in the case of headlamp with a passing beam, one or more driving beams and a front fog lamp:

(i) the headlamp shall be subjected to the following cycle until the time specified is reached:

- 15 minutes, passing-beam filament lit;
- 5 minutes, all functions lit.

(ii) if the applicant declares that the headlamp is to be used with only the passing beam lit or only the driving beam(s) {See note under D-1.1.1.1 (b)} lit at a time, the test shall be carried out in accordance with this condition, activating {See note under D-1.1.1.1 (a)} successively the passing beam half of the time and the driving beam(s) for half the time specified in D-1.1 above, while the front fog lamp is subjected to a cycle of 15 minutes off and 5 minutes lit for half of the time and during the operation of the driving beam;

(iii) if the applicant declares that the headlamp is to be used with only the passing

beam lit or only the front fog lamp {See note under D-1.1.1.1 (b)} lit at a time, the test shall be carried out in accordance with this condition, activating {See note under D-1.1.1.1 (a)} successively the passing beam half of the time and the front fog lamp for half of the time specified in D-1.1 above, while the driving beam(s) is(are) subjected to a cycle of 15 minutes off and 5 minutes lit for half of the time and during the operation of the passing beam;

(iv) if the applicant declares that the headlamp is to be used with only the passing beam lit or only the driving beam(s) {See note under D-1.1.1.1 (b)} lit or only the front fog lamp {See note under D-1.1.1.1 (b)} lit at a time, the test shall be carried out in accordance with this condition, activating {See note under D-1.1.1.1 (a)} successively the passing beam one third of the time, the driving beam(s) one third of the time and the front fog lamp for one third of the time specified in D-1.1 above.

(e) In the case of a headlamp having additional light source(s) used to produce bend lighting, except for additional lighting unit(s), it (they) shall be switched on for one minute, and switched off for nine minutes during the activation of the principal passing beam.

D-1.1.1.2. Test voltage

If the headlamp has several additional light sources used to produce bend lighting, the test shall be carried out with the combination of light source(s) that represents the most severe operating condition

The voltage shall be applied to the terminals of the test sample as follows:

(a) In case of replaceable filament light source(s) operated directly under vehicle voltage system conditions:

The test shall be performed at 6.3 V, 13.2 V or 28.0 V as applicable except if the applicant specifies that the test sample may be used at a different voltage. In this case, the test shall be carried out with the filament light source operated at the highest voltage that can be used.

(b) In case of replaceable gas discharge light source(s): The test voltage for the electronic light source control-gear or the light source in case the ballast is integrated with the light source, is 13.2 ± 0.1 volts for 12 V vehicle voltage systems, or otherwise specified in the application for approval.

(c) In the case of non-replaceable light sources operated directly under vehicle voltage system conditions: All measurements on lighting units equipped with non-replaceable light sources (filament light sources and/or others) shall be made at 6.3 V, 13.2 V or 28.0 V or at other voltages according to the vehicle voltage system as specified by the applicant respectively.

(d) In the case of light sources, replaceable or non-replaceable, being operated independently from vehicle supply voltage and fully controlled by the system, or, in the case of light sources supplied by a supply and operating device, the test voltages as specified above shall be applied to the input terminals of that device. The test laboratory may require from the manufacturer the supply and operating device or a special power supply

needed to supply the light source(s).

(e) LED module(s) shall be measured at 6.75 V, 13.2 V or 28.0 V respectively, if not otherwise specified within this Standard, LED module(s) operated by an electronic light source control gear, shall be measured as specified by the applicant.

(f) Where signaling lamps are grouped, combined or reciprocally incorporated into the test sample and operating at voltages other than the nominal rated voltages of 6 V, 12 V or 24 V respectively, the voltage shall be adjusted as declared by the manufacturer for the correct photometric functioning of that lamp.

D-1.1.2. Test results

D-1.1.2.1. Visual inspection

Once the headlamp has been stabilized to the ambient temperature, the headlamp lens and the external lens, if any, shall be cleaned with a clean, damp cotton cloth. It shall then be inspected visually; no distortion, deformation, cracking or change in colour of either the headlamp lens or the external lens, if any, shall be noticeable.

D-1.1.2.2. Photometric test

To comply with the requirements of this standard, the photometric values shall be verified in the following points:

For Class B headlamp:

Passing beam: 50R - 50L - **0.50U/1.5L and 0.50U/1.5R** Driving beam: Point of Emax

For Class C, D and E headlamps:

Passing beam: 0.86D/3.5R - 0.86D/3.5L - 0.50U/1.5L and 1.5 R Driving beam: Point of Emax

Another aiming may be carried out to allow for any deformation of the headlamp base due to heat (the change of the position of the cut-off line is covered in D-2 of this annex) **except for points 0.50U/1.5L and 0.50U/1.5R**. A 10 per cent discrepancy between the photometric characteristics and the values measured prior to the test is permissible including the tolerances of the photometric procedure. **The value measured at points 0.50U/1.5L and 0.50U/1.5R shall not exceed the photometric value measured prior to the test by more than 255 cd.**

D-1.2. Dirty headlamp

After being tested as specified in D-1.1 above, the headlamp shall be operated for one hour as described in D-1.1.1., after being prepared as prescribed in D-1.2.1., and checked as prescribed in D-1.1.2.

D-1.2.1. Preparations of the headlamp

D-1.2.1.1. Test mixture

Same as D-1.2.1.1.1 to D-1.2.1.1.4 of Annex D of Part 1.

[Cross reference of this clause to be reviewed after part 1 revision is prepared and finalized as per ECR 112.]

D-1.2.1.2. **Application of the test mixture to the headlamp**

The test mixture shall be uniformly applied to the entire light-emitting surface of the headlamp and then left to dry.

This procedure shall be repeated until the illumination value has dropped to 15-20 per cent of the values measured for each following point under the conditions described in this annex:

For Class B headlamp:

Passing beam/driving beam and driving beam only: Point of Emax

Passing beam only: B 50 and 50 V

For Class C D and E headlamps

Passing beam/driving beam and driving beam only: Point of Emax

Passing beam only: 0.50U/1.5L & 1.5R and 0.86D/V

D-2. **Test for change in vertical position of the cut-off line under the influence of heat**

This test consists of verifying that the vertical drift of the cut-off line under the influence of heat does not exceed a specified value for an operating **headlamp producing a passing beam**

The headlamp tested in accordance with D-1, shall be subjected to the test described in D-2.1., without being removed from or readjusted in relation to its test fixture.

D-2.1. TEST

The test shall be carried out in a dry and still atmosphere at an ambient temperature of $23^{\circ}\text{C} \pm 5^{\circ}\text{C}$.

Using a mass production filament lamp(s) which has been aged for at least one hour or a mass production gas-discharge light source which has been aged for at least 15 hours or **the LED module(s) as submitted with the headlamps, which has (have) been aged for at least 48 hours**, the headlamp shall be operated on passing beam without being dismantled from or readjusted in relation to its test fixture. (For the purpose of this test, the voltage shall be adjusted as specified in paragraph 1.1.1.2.). The position of the "cut-off" line in its horizontal part (between the vertical lines passing through point 50 L and 50 R for Class B headlamp, 3.5 L and 3.5 R for Classes C, D and E headlamp) shall be verified 3 minutes (r3) and 60 minutes (r60) respectively after operation.

The measurement of the variation in the "cut-off" line position as described above shall be carried out by any method giving acceptable accuracy and

reproducible results.

D-2.2.

Test results

Same as D-2.2.of Annex D of Part 1 of this standard.

[Cross reference of this clause to be reviewed after part 1 revision is prepared and finalized as per ECR 112.]

ANNEX E

(See 9.2)

MINIMUM REQUIREMENTS FOR CONFORMITY OF
PRODUCTION CONTROL PROCEDURES

- E-1. General
- E-1.1. The conformity requirements shall be considered satisfied from a mechanical and a geometrical standpoint, if the differences do not exceed inevitable manufacturing deviations within the requirements of this standard. This condition also applies to colour.
- E-1.2. For Class A, B, C and D headlamp.
- E-1.2.1 With respect to photometric performances, the conformity of mass-produced headlamps shall not be contested if, when testing photometric performances of any headlamp chosen at random and equipped with standard filament lamp(s) **and/or (a) LED module(s), as present in the lamp:**
- E-1.2.2 Class A headlamp: No measured value deviates unfavourably by more than 20 per cent from the value prescribed in this standard.
- E-1.2.3. Class B, C and D headlamp
- E-1.2.3.1. No measured value deviates unfavourably by more than 20 per cent from the value prescribed in this Standard. For values **in zone I** for Class-B, **C and D** headlamp, for Classes headlamps, the maximum unfavourable deviation may be respectively:
- 255 cd equivalent 20 per cent**
- 380 cd equivalent 30 per cent**
- E 1.2.3.2.** And if, for the driving beam, a tolerance of + 20 per cent for maximum values and - 20 per cent for minimum values is observed for the photometric values at any measuring point specified in 6.2.3.2 and 6.3.2.2 of this standard.
- E 1.2.4 **If, in the case of a lamp equipped with a replaceable filament light source according to AIS 034 part 1 Rev 1,** the results of the tests described above do not meet the requirements, tests shall be repeated using another standard filament lamp(s).
- E 1.2.5 If the results of the tests described above do not meet the requirements, the alignment of the headlamp may be changed, provided that the axis of the beam is not displaced laterally by more than 0.5 degree to the right or left and not by more than 0.2 degree up or down.**
- E-1.3. For Class E headlamp:

E 1.3.1. For Class E headlamps measured at 13.2 V 0.1 V, or as otherwise specified and equipped with:

(a) A removable standard gas-discharge light source according to **Standard AIS 034 Part2 rev 1** In this case the luminous flux of this gas-discharge light source may differ from the reference luminous flux specified in **AIS 034 (Part 2) (Rev.1)** and the illuminances shall be corrected accordingly; or

(b) A serial production gas-discharge light source and a serial ballast. In this case the luminous flux of this light source may deviate from the nominal luminous flux due to light source and ballast tolerances as specified in **AIS 034 (Part 2) (Rev.1)** and accordingly the measured illuminances may be corrected by 20 per cent in the favorable direction; or

(c) LED modules as present in the lamp

The conformity of mass produced headlamps, chosen at random and equipped with a Gas Discharged lamp and / or LED module(s) present in the headlamp, with respect to photometric performance shall not be contested provided that;

E 1.3.2. No measured value deviates unfavourably by more than 20 per cent from the value prescribed in this Standard, For values in zone 1, the maximum unfavourable deviation may be respectively:

255 cd equivalent 20 per cent

380 cd equivalent 30 per cent

E 1.3.3. And if, for the driving beam, a tolerance of + 20 per cent for maximum values and - 20 per cent for minimum values is observed for the photometric values at any measuring point specified in 6.3.2.1 and 6.3.2.2 of this standard.

E-1.3.4. If the results of the tests described above do not meet the requirements, the alignment of the headlamp may be changed, provided that the axis of the beam is not displaced laterally by more than 0.5 degrees to the right or left and not by more than 0.2 degrees up or down.

E-1.3.5. If the results of the tests described above do not meet the requirements, tests on the headlamp shall be repeated using another standard gas discharge light source, gas-discharge light source and/or ballast **or LED module and electronic light source control gear**, whichever is applicable according to paragraph 1.3.1. above.

E 1.4. With respect to the verification of the change in vertical position of the "cut-off" line under the influence of heat, the following procedure shall be applied (Classes B, C, D and E headlamps only):

One of the sampled headlamps shall be tested according to the procedure described in D 2.1. of Annex 4 **D** after being subjected three consecutive times to the cycle described in . **D 2.2.** of Annex 4 **D**.

The headlamp shall be considered as acceptable if Δr does not exceed 1.5 mrad. If this value exceeds 1.5 mrad but is not more than 2.0 mrad a second sample

shall be subjected to the test after which the mean of the absolute values recorded on both samples shall not exceed 1.5 mrad.

- E-1.5 Headlamps with apparent defects are disregarded.
- E-1.6 If, however, for a series of samples vertical adjustment cannot be performed repeatedly to the required position within the allowed tolerances, the quality of "cut-off" shall be tested on one of the headlamps from the series of samples, according to the procedure described in J-2 and J-4 of Annex J.
- E-2. Minimum requirements for verification of conformity by the manufacturer For each type of headlamp the holder of the approval mark shall carry out at least the following tests, at appropriate intervals. The tests shall be carried out in accordance with the provision of this standard.
- If any sampling shows non-conformity with regard to the type of test concerned, further samples shall be taken and tested. The manufacturer shall take steps to ensure the conformity of the production concerned.
- E-2.1. Nature of tests
- Tests of conformity in this standard shall cover the photometric characteristics and for Class B, C, D and E headlamps the verification of the change in vertical position of the cut-off line under influence of heat.
- E-2.2. Methods used in tests
- Same as E-2.2.of Annex E of Part 1 of this standard.
- [Cross reference of this clause to be reviewed after part 1 revision is prepared and finalized as per ECR 112.]
- E-2.3. Nature of sampling
- Same as E-2.3.of Annex E of Part 1 of this standard.
- [Cross reference of this clause to be reviewed after part 1 revision is prepared and finalized as per ECR 112.]
- E-2.4. Measured and recorded photometric characteristics
- The sampled headlamps shall be subjected to photometric measurements at the points provided for in the standard, the reading being limited at the points:
- E-2.4.1. For Class A headlamps: HV, LH, RH, 12.5L and 12.5R
- E-2.4.2. For Class B headlamps: Emax, HV (See note below) in the case of the driving beam, and to the points HV, **0.86D/3.5R**, **0.86D/3.5L**, in the case of the passing beam.
- Note : When the driving beam is reciprocally incorporated with the passing beam, HV in the case of the driving beam shall be the same measuring point as in the case of the passing beam.
- E-2.4.3 For Class C, D and E headlamps: Emax, HV, (See note below E-2.4.2.) in the

case of the driving beam, and to the points HV, 0.86D/3.5R, 0.86D/3.5L, in the case of the passing beam.

E-2.5. Criteria governing acceptability

The manufacturer is responsible for carrying out a statistical study of the test results and for defining, in agreement with the testing agency, criteria governing acceptability of his products in order to meet the specification laid down for verification of conformity of products in 9.1 of this standard.

The criteria governing acceptability shall be such that, with a confidence level of 95 per cent, the minimum probability of passing a spot check in accordance with Annex G (first sampling) would be 0.95.

ANNEX F

(See 5.6)

REQUIREMENTS FOR LAMPS INCORPORATING LENSES OF PLASTIC MATERIAL - TESTING OF LENS OR MATERIAL SAMPLES AND OF COMPLETE HEADLAMPS

- F-1 General specifications
- F-1.1 The samples supplied pursuant to 2.2.4 of this standard shall satisfy the specifications indicated in F-2.1 to F-2.5 below.
- F-1.2 The two samples of complete headlamps supplied pursuant to 2.2.3 of this standard and incorporating lenses of plastic material shall, with regard to the lens material, satisfy the specifications indicated in F-2.6 below.
- F-1.3 The samples of lenses of plastic material or samples of material shall be subjected, with the reflector to which they are intended to be fitted (where applicable), to approval tests in the chronological order indicated in A of Table F1 of this Annex.
- F-1.4 However, if the headlamp manufacturer can prove that the product has already passed the tests prescribed in F-2.1 to F-2.5 below, or the equivalent tests pursuant to another standard, those tests need not be repeated; only the tests prescribed in B of Table F-1, shall be mandatory.
- F-2 Test
- F-2.1 Resistance to temperature changes
- F-2.1.1 Tests
- Same as F-2.1.1 of Annex F of Part 1 of this standard.
- [Cross reference of this clause to be reviewed after part 1 revision is prepared and finalized as per ECR 112.]
- F-2.1.2 Photometric measurements
- F- 2.1.2.1. Method
- Photometric measurements shall be carried out on the samples before and after the test.
- These measurements shall be made using a standard (étalon) lamp, a standard gas-discharge light source or (an) LED module(s) as present in the headlamp, at the following points:
- B 50, 50L and 50R for Class B headlamp, 0.86D/3.5R, 0.86D/3.5L, 0.50U/1.5L and 1.5R for Classes C, D and E headlamp for the passing beam or a passing/driving lamp;

Imax for the driving beam of a driving lamp or a passing/driving lamp;

F-2.1.2.2 Results

Same as F-2.1.2.2 of Annex F of Part 1 of this standard.

[Cross reference of this clause to be reviewed after part 1 revision is prepared and finalized as per ECR 112.]

F-2.2 Resistance to atmospheric and chemical agents

F-2.2.1 Resistance to atmospheric agents

Same as F-2.2.1 of Annex F of Part 1 of this standard.

[Cross reference of this clause to be reviewed after part 1 revision is prepared and finalized as per ECR 112.]

F-2.2.2 Resistance to chemical agents:

Same as F-2.2.2 and F-2.2.3. of Annex F of Part 1 of this standard.

[Cross reference of this clause to be reviewed after part 1 revision is prepared and finalized as per ECR 112.]

F-2.3 Resistance to detergents and hydrocarbons

F-2.3.1 Same as F-2.3 of Annex F of Part 1 of this standard.

[Cross reference of this clause to be reviewed after part 1 revision is prepared and finalized as per ECR 112.]

F-2.4 Resistance to mechanical deterioration

Same as F-2.4 of Annex F of Part 1 of this standard.

[Cross reference of this clause to be reviewed after part 1 revision is prepared and finalized as per ECR 112.]

F-2.5 Test of adherence of coatings, if any

F-2.5.1 to

F-2.5.3.

Same as F-2.5.1 to 2.5.3 of Annex F of Part 1 of this standard.

[Cross reference of this clause to be reviewed after part 1 revision is prepared and finalized as per ECR 112.]

F-2.6 Tests of the complete headlamp incorporating a lens of plastic material

F-2.6.1 Resistance to mechanical deterioration of the lens surface

F-2.6.1.1 Tests

The lens of headlamp sample No. 1 shall be subjected to the test described in F-

2.4.1 of Annex F of Part 1 of this standard.

[Cross reference of this clause to be reviewed after part 1 revision is prepared and finalized as per ECR 112.]

F-2.6.1.2 Results

After the test, the results of photometric measurements carried out on the headlamp in accordance with this standard shall not exceed:

(a) by more than 30 per cent the maximum values prescribed at point HV and not be more than 10 per cent below the minimum values prescribed at point 50 L and 50 R for Class B headlamp, 0.86D/3.5R, 0.86D/3.5L for Class C, D and E headlamp.

(b) By more than 10 per cent below the minimum values prescribed for HV in the case of a headlamp producing driving beam only.

F- 2.6.2. Test of adherence of coatings, if any

Same as F-2.6.2 of Annex F of Part 1 of this standard.

[Cross reference of this clause to be reviewed after part 1 revision is prepared and finalized as per ECR 112.]

F-2.7. RESISTANCE TO LIGHT SOURCE RADIATIONS

Flat samples of each light transmitting plastic component of the headlamp are exposed to the light of the LED module(s) or the gas-discharge light source. The parameters such as angles and distances of these samples shall be the same as in the headlamp. These samples shall have the same colour and surface treatment, if any, as the parts of the headlamp.

After 1,500 hours of continuous operation, the colorimetric specifications of the transmitted light must be met, and the surfaces of the samples shall be free of cracks, scratches, scalings or deformation.

F-3 Verification of the Conformity of Production

F-3.1 Same as F-3 of Annex F of Part 1.

[Cross reference of this clause to be reviewed after part 1 revision is prepared and finalized as per ECR 112.]

F-4 Method of Measurement of the Diffusion and Transmission of Light

Same as F-4 of Annex F of Part 1.

[Cross reference of this clause to be reviewed after part 1 revision is prepared and finalized as per ECR 112.]

F-5 Spray Testing Method

Same as F-5 of Annex F of Part 1.

[Cross reference of this clause to be reviewed after part 1 revision is prepared and

finalized as per ECR 112.]

F-6 Adhesive Tape Adherence Test

Same as F-6 of Annex F of Part 1.

[Cross reference of this clause to be reviewed after part 1 revision is prepared and finalized as per ECR 112.]

Table F-1
(See F-1.3 and F-1.4)

CHRONOLOGICAL ORDER OF APPROVAL TESTS

A. Tests on plastic materials (lenses or samples of material supplied pursuant to paragraph 2.2.4. of this standard).

Tests	Samples		Lenses or samples of material								Lenses			
	1	2	3	4	5	6	7	8	9	10	11	12	13	14
1.1. Limited photometry (para. 2.1.2.)											x	x	x	
1.1.1. Temperature change (para. 2.1.1.)											x	x	x	
1.1.2. Limited photometry (para. 2.1.2.)											x	x	x	
1.2.1. Transmission measurement	x	x	x	x	x	x		x	x	x				
1.2.2. Diffusion measurement	x	x	x					x	x	x				
1.3. Atmospheric agents (para. 2.2.1.)	x	x	x											
1.3.1. Transmission measurement	x	x	x											
1.4. Chemical agents (para. 2.2.2.)	x	x	x											
1.4.1. Diffusion measurement	x	x	x											
1.5. Detergents (para. 2.3.1.)				x	x	x								
1.6. Hydrocarbons (para. 2.3.2.)				x	x	x								
1.6.1. Transmission measurement				x	x	x								
1.7. Deterioration (para. 2.4.1.)								x	x	x				
1.7.1. Transmission measurement								x	x	x				
1.7.2. Diffusion measurement								x	x	x				
1.8. Adherence (para. 2.5.)														x
1.9. Resistance to light source radiations (para. 2.7.)							x							

B. Tests on complete headlamps (supplied pursuant to paragraph 2.2.3. of this standard).

Tests	Complete headlamp	
	Sample No.	
	1	2
2.1. Deterioration (para. 2.6.1.1.)	x	
2.2. Photometry (para. 2.6.1.2.)	x	
2.3. Adherence (para. 2.6.2.)		x

ANNEX G

(See 9.3)

MINIMUM REQUIREMENTS FOR SAMPLING BY TESTING AGENCY

- G-1. General
- G-1.1. The conformity requirements shall be considered satisfied from a mechanical and a geometrical standpoint in accordance with the requirements of this standard, if any, if the differences do not exceed inevitable manufacturing deviations. This condition also applies to colour.
- G-1.2. For Class A, B, C and D headlamp:
- G-1.2.1. With respect to photometric performances, the conformity of mass-produced headlamps shall not be contested if, when testing photometric performances of any headlamp chosen at random and equipped with a standard filament lamp, **LED module(s) as present in the headlamp:**
- G-1.2.2. Class A headlamps: no measured value deviates unfavourably by more than 20 per cent from the value prescribed in this standard.
- G-1.2.3. Class B, C and D headlamps:
- G 1.2.3.1. No measured value deviates unfavourably by more than 20 per cent from the value prescribed in this **Standard**. For values in zone **I** for Classes **B, C and D headlamps, the maximum unfavourable** deviation may be respectively:
255 cd equivalent 20 per cent
380 cd equivalent 30 per cent
- G-1.2.3.2. And if for the driving beam a tolerance of + 20 per cent for maximum values and - 20 per cent for minimum values is observed for the photometric values at any measuring point specified in 6.2.3.2 and 6.3.2.2 of this standard.
- G-1.2.4. If the results of the tests described above do not meet the requirements, tests shall be repeated using another standard filament lamp.
- G.1.2.5. If the results of the tests described above do not meet the requirements, the alignment of the headlamp may be changed, provided that the axis of the beam is not displaced laterally by more than 0.5 degrees to the right or left and not by more than 0.2 degrees up or down.**
- G-1.3. For Class E headlamp:
- 1.3.1. For Class E headlamps measured at **13.2 V** ± 0.1 V, or as otherwise specified, and equipped with:
- (a) a removable standard gas-discharge light source according to **AIS 034 (Part 2) (Rev 2)** In this case the luminous flux of this gas-discharge light source may differ from the reference luminous flux specified in **AIS 034 (Part 2) (Rev**

2) and the illuminances shall be corrected accordingly;

or

(b) a serial production gas-discharge light source and a serial ballast. In this case the luminous flux of this light source may deviate from the nominal luminous flux due to light source and ballast tolerances as specified in **AIS 034 (Part 2) (Rev 2)** and accordingly the measured illuminances may be corrected by 20 per cent in the favourable direction;

or

(c) LED modules as present in the lamp;

the conformity of mass-produced headlamps, chosen at random and equipped with a Gas Discharge lamp and / or LED module(s) present in the headlamp, with respect to photometric performance shall not be contested provided that;

1.3.2. No measured value deviates unfavourably by more than 20 per cent from the value prescribed in this **Standard**. For values in zone 1, the maximum unfavourable deviation may be respectively:

255 cd equivalent 20 per cent

380 cd equivalent 30 per cent.

G-1.3.3. And if, for the driving beam, a tolerance of + 20 per cent for maximum values and - 20 per cent for minimum values is observed for the photometric values at any measuring point specified in 6.3.2.1 and 6.3.2.2 of this standard

G-1.3.4. If the results of the tests described above do not meet the requirements, the alignment of the headlamp may be changed, provided that the axis of the beam is not displaced laterally by more than 0.5 degrees to the right or left and not by more than 0.2 degrees up or down..

G-1.3.5. If the results of the tests described above do not meet the requirements, tests on the headlamp shall be repeated using another standard gas-discharge light source or gas-discharge light source and ballast or, **(an) LED module(s) and electronic light source control gear(s)**, whatever is applicable according to G-1.3.1 above.

G-1.4 Headlamps with apparent defects are disregarded.

G-1.5 If, however, for a series of samples vertical adjustment cannot be performed repeatedly to the required position within the allowed tolerances, the quality of "cut-off" shall be tested on one of the headlamps from the series of samples, according to the procedure described in J-2 and J-4 Annex J.

G-2. **FIRST SAMPLING**

In the first sampling four headlamps are selected at random.

The first sample of two is marked A, the second sample of two is marked B.

G-2.1. The conformity is not contested

G-2.2.1. Same as G-2.2.1 to G-2.2.1.2 of Annex G of Part 1 of this standard

[Cross reference of this clause to be reviewed after part 1 revision is prepared and finalized as per ECR 112.]

G-2.2. The conformity is contested

G-2.2.1. Same as G-2.2.1 to G-2.2.1.2 of Annex G of Part 1 of this Standard

[Cross reference of this clause to be reviewed after part 1 revision is prepared and finalized as per ECR 112.]

G-2.3. Non conformity established

Conformity shall be contested and conditions of 10 applied if, following the sampling procedure shown in Figure G-1 of this annex the deviations of the measured values of the headlamps are:

G-2.3.1. Same as G-2.3.1 of Annex G of Part 1 of this standard.

[Cross reference of this clause to be reviewed after part 1 revision is prepared and finalized as per ECR 112.]

G-2.3.2. Same as G-2.3.2 of Annex G of Part 1 of this standard.

[Cross reference of this clause to be reviewed after part 1 revision is prepared and finalized as per ECR 112.]

G-3. Repeated Sampling

Same as G-3 of Annex G of Part 1 of this standard.

[Cross reference of this clause to be reviewed after part 1 revision is prepared and finalized as per ECR 112.]

G-3.1. The conformity is not contested

G-3.1.1. Same as G-3.1.1, to G-3.1.1.2 of Annex G of Part 1 of this standard.

[Cross reference of this clause to be reviewed after part 1 revision is prepared and finalized as per ECR 112.]

G-3.1.1.1. sample C

G-3.2. The conformity is contested

G-3.2.1. Same as G-3.2.1, G-3.2.1.1. of Annex G of Part 1 of this standard.

[Cross reference of this clause to be reviewed after part 1 revision is prepared and finalized as per ECR 112.]

G-3.3. Non Compliance Established.

Conformity shall be contested and conditions of 10 applied if, following the sampling procedure shown in Figure G-1 of this annex **AIS-010 (Part 1)(Rev. 2)**, the deviations of the measured values of the headlamps are:

G-3.3.1. **Same as G-3.3.1 and G-3.3.2 of Annex G of Part 1 of this standard.**

[Cross reference of this clause to be reviewed after part 1 revision is prepared and finalized as per ECR 112.]

Figure G-1

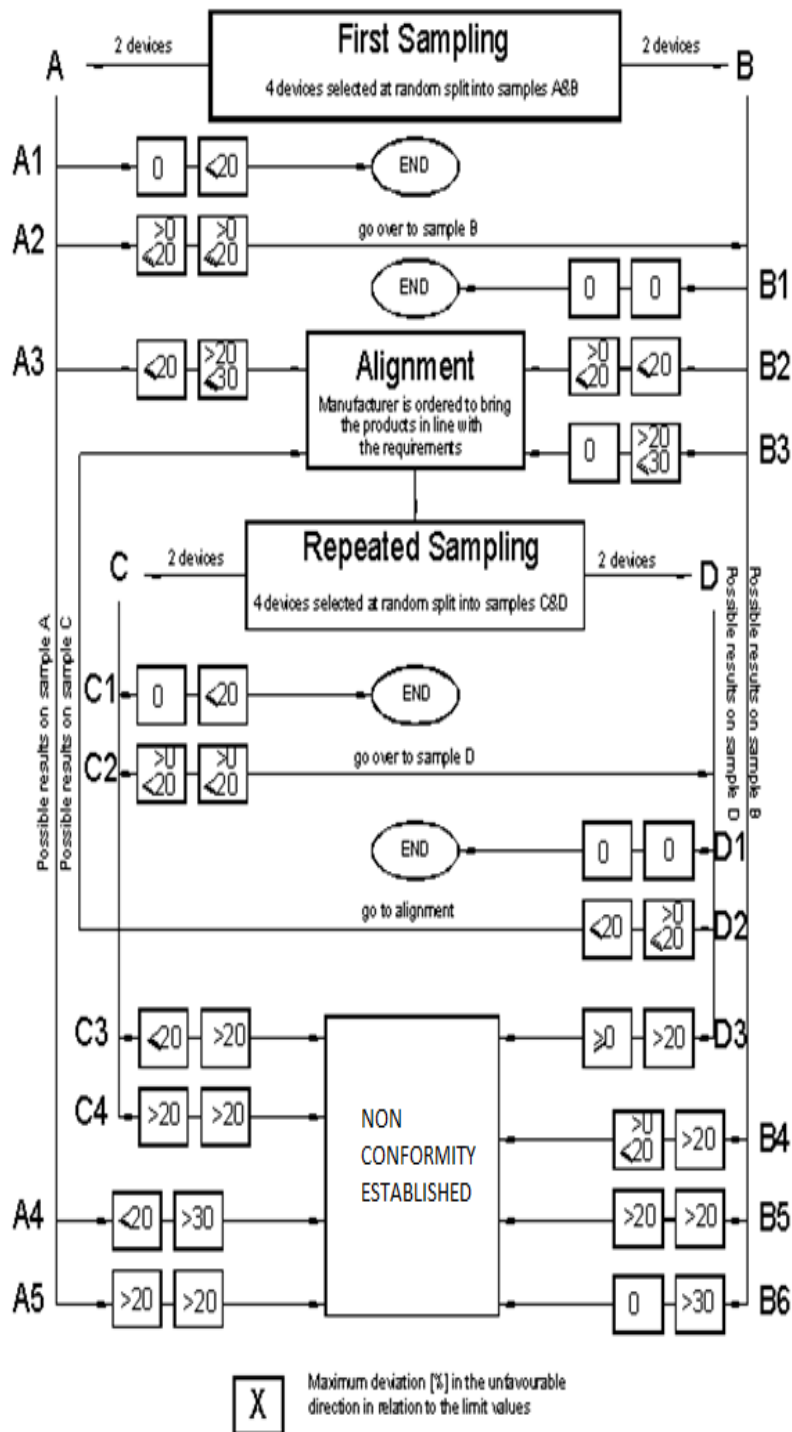

**ANNEX H
(See D-1.1 of Annex D)**

**OVERVIEW OF OPERATIONAL PERIODS CONCERNING TEST
FOR STABILITY OF PHOTOMETRIC PERFORMANCE**

Abbreviations:

P: passing beam lamp

D: driving beam lamp (D1 + D2 means two driving beams)

F: front fog lamp

- - - - - : means a cycle of 15 minutes off and 5 minutes lit. **means a cycle of 15 minutes off and 5 minutes lit.**

-----: means a cycle of 9 minutes off and 1 minutes lit.

All following grouped headlamps and front fog lamps together with the added class B marking symbols are given as examples and are not exhaustive.

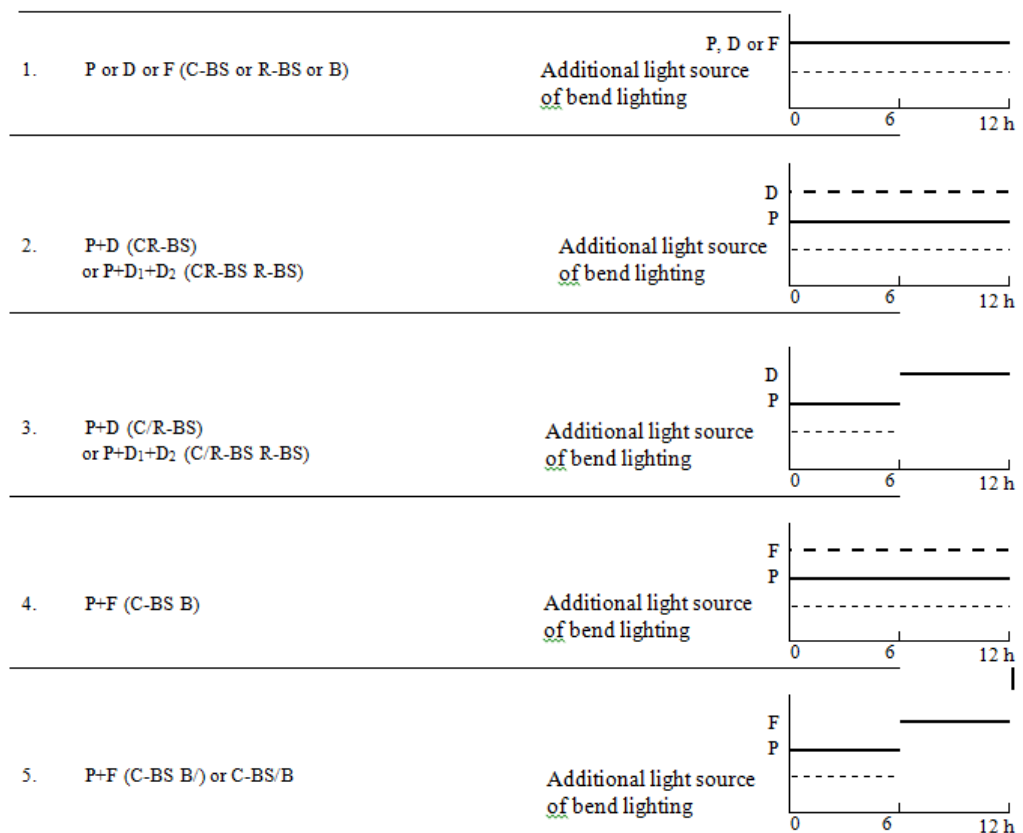

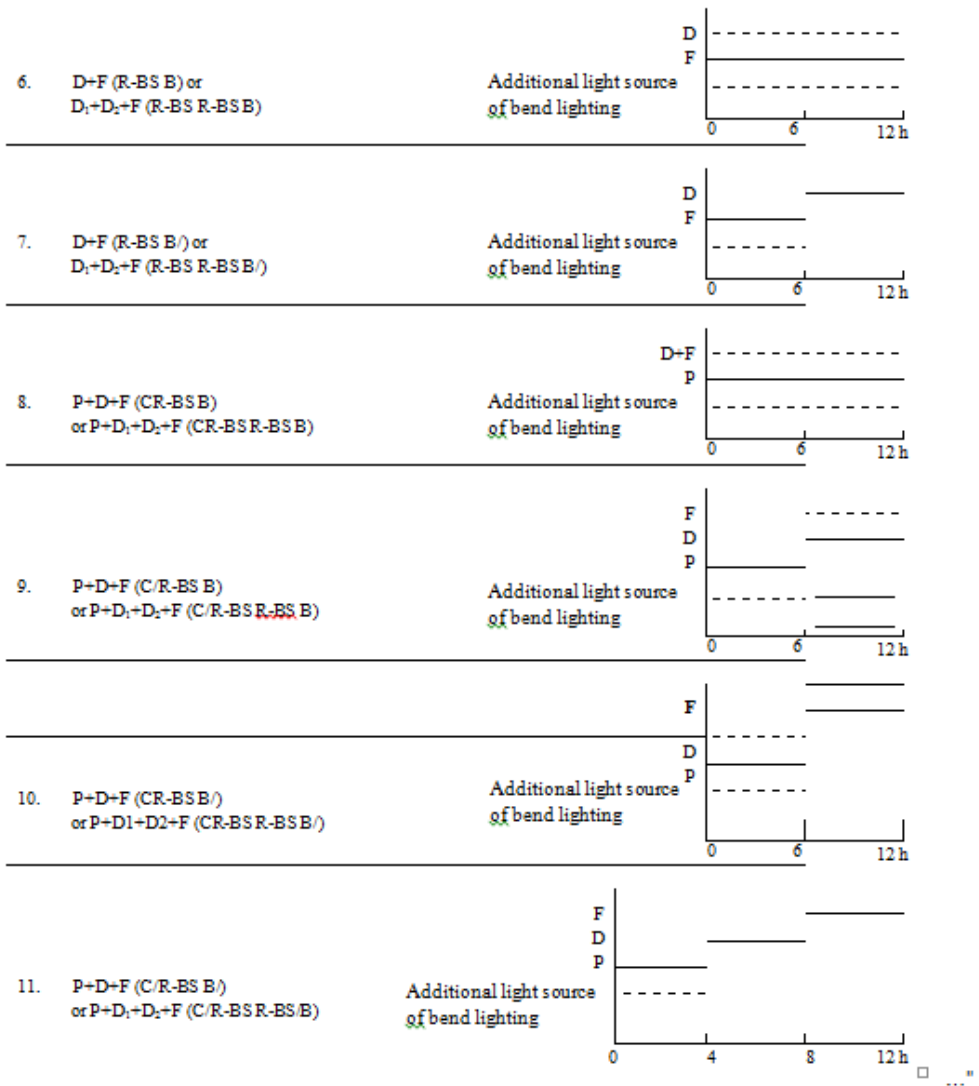

□ ..."

ANNEX J
(See 6.2.1 & E-1.6)

**DEFINITION AND SHARPNESS OF THE "CUT-OFF" LINE FOR
SYMMETRICAL PASSING-BEAM HEADLAMPS AND AIMING
PROCEDURE BY MEANS OF THIS "CUT-OFF" LINE**

- J-1. General
- J-1.1. The luminous intensity distribution of the symmetrical passing beam headlamps shall incorporate a "cut-off" line which enables the symmetrical passing-beam headlamp to be adjusted correctly for the photometric measurements and for the aiming on the vehicle. The characteristics of the "cut-off" line shall comply with the requirements set out in J-2 to J-4 below:
- J-2. Shape of the "Cut-off" line
- J-2.1. For visual adjustment of the symmetrical passing-beam headlamp the cut-off line shall provide: a horizontal line for vertical adjustment of the symmetrical passing-beam headlamp extending to either side of the v-v-line (see Figure 1) as specified in 6.2.1 of this standard.

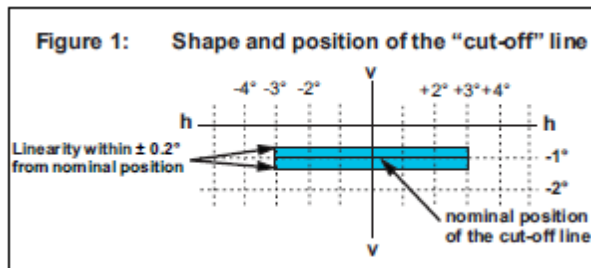

- J-3. Adjustment of the symmetrical passing-beam headlamp:
- J-3.1. Horizontal adjustment: The beam with the "cut-off" line shall be so positioned that the projected beam pattern appears approximately symmetrical to the v-v-line.
- J-3.2. Vertical adjustment: After horizontal adjustment of the symmetrical passing-beam headlamp according to J-3.1 above, the vertical adjustment shall be performed in such a way that the beam with its cut-off line is moved upwards from the lower position until the cut-off line is situated at nominal vertical position. For nominal vertical adjustment the cut-off line is positioned on the v-v-line at 1 percent below the h-h-line.
- If the horizontal part is not straight but slightly curved or inclined, the cut-off line shall not exceed the vertical range formed by two horizontal lines which are situated from 3° left to 3° right of the vv- line at 0.2° for class B and 0.3° for class A, C, D and E head lamps above and below the nominal position of the

cut-off (see Figure 1).

J-3.3. When the vertical adjustments of three different individuals differs by more than 0.2° for class B and 0.3° for class A, C, D and E head lamps, the horizontal part of the cut-off line is assumed not to provide sufficient linearity or sharpness for performing visual adjustment. In this case the quality of cut-off shall be tested instrumentally for compliance with requirements as follows.

J-4. Measurement of the quality of “Cut-off”

J-4.1 Measurements shall be performed by vertically scanning through the horizontal part of the cut-off line in angular steps not exceeding 0.05°

(a) - at either a measurement distance of 10 m and a detector with a diameter of approximately 10 mm.

(b) - or at a measurement distance of 25 m and a detector with a diameter of approximately 30 mm.

The measurement of the cut-off quality shall be considered acceptable if the requirements of the J-4.1.2 shall comply with at least one measurement at 10 m or 25 m. The measuring distance at which the test was determined shall be noted down in the test report.

The scanning is performed from its lower position upwards through the cut-off line along the vertical lines at -3° to -1.5° , $+1.5^\circ$ to $+3^\circ$ from the v-v-line. When so measured, the quality of the “cut-off” line shall meet the following requirements:

J-4.1.1. Not more than one cut-off line shall be visible.

J-4.1.2. Sharpness of cut-off: if scanned vertically through the horizontal part of the cut-off line along the $\pm 2.5^\circ$ -lines, the maximum value measured for: $G = (\log EV - \log E(V + 0.1^\circ))$ is called the sharpness factor G of the cut-off line. The value of G shall not be less than 0.13 for class B and 0.08 for classes A, C, D and E

J-4.1.3. Linearity: the part of the cut-off line which serves for vertical adjustment shall be horizontal from $3^\circ L$ to $3^\circ R$ of the v-v-line. This requirement is deemed to be met if the vertical positions of the inflection points according to J-3.2 above at 3° left and right of the v-v-line do not differ by more than 0.2° for class B and 0.3° for class A, C, D and E head lamps from the nominal position at the v-v-line.

J-5. Instrumental vertical adjustment: if the cut-off line complies with the above quality requirements, the vertical beam adjustment can be performed instrumentally. For this purpose the inflection point where $d^2(\log E) / dv^2 = 0$ is positioned on the v-v-line in its nominal position below the h-h-line. The movement for measuring and adjusting the “cut-off” line shall be upwards from below the nominal position.

Annex K

ANNEX K
CENTRE OF REFERENCE

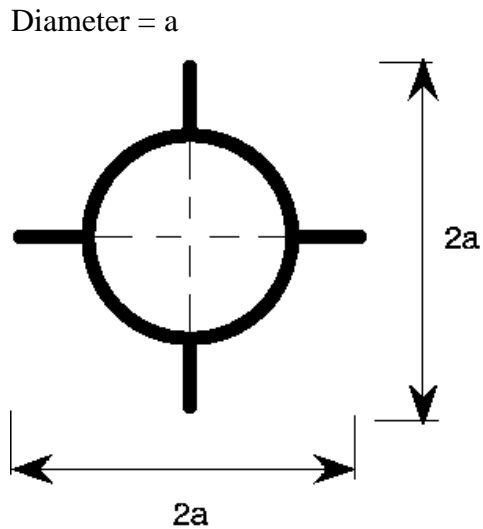

$a = 2 \text{ mm min.}$

[In ECE 2mm dimension is deleted. Can we retain this?]

This optional mark of the centre of reference shall be positioned on the lens at its intersection with the reference axis of the passing beam, and also on the lenses of the driving beams when they are neither grouped nor combined nor reciprocally incorporated with a passing beam.

The above drawing represents the mark of the centre of reference as projected on a plane substantially tangent to the lens about the centre of the circle. The lines constituting this mark may either be solid or dotted.

Annex L

ANNEX L

(See 3.5)

VOLTAGE MARKINGS

Voltage markings



This marking must be placed on the main body of each headlamp containing only gas discharge light sources and ballast, and on each external part of the ballast.

The ballast(s) is(are) designed for a ** Volts network system.

This marking must be placed on the main body of each headlamp containing at least one gas discharge light source and ballast.

The ballast(s) is(are) designed for a ** Volts network system.

None of the filament lamps which the headlamp contains is designed for a 24 Volts network system.

**Annex M
(see 5.3.3.2)**

**REQUIREMENTS FOR LED MODULES AND HEADLAMPS
INCLUDING LED MODULES**

1. GENERAL SPECIFICATIONS

- 1.1. Each LED module sample submitted shall conform to the relevant specifications of this standard when tested with the supplied electronic light source control-gear(s), if any.**
- 1.2. LED module(s) shall be so designed as to be and to remain in good working order when in normal use. They shall moreover exhibit no fault in design or manufacture. A LED module shall be considered to have failed if any one of its LEDs has failed.**
- 1.3. LED module(s) shall be tamperproof.**
- 1.4. The design of removable LED module(s) shall be such that:**
 - 1.4.1. When the LED module is removed and replaced by another module provided by the applicant and bearing the same light source module identification code, the photometric specifications of the headlamp shall be met;**
 - 1.4.2. LED modules with different light source module identification codes within the same lamp housing, shall not be interchangeable.**

2. MANUFACTURE

- 2.1. The LED(s) on the LED module shall be equipped with suitable fixation elements.**
- 2.2. The fixation elements shall be strong and firmly secured to the LED(s) and the LED module.**

3. TEST CONDITIONS

3.1. APPLICATION

- 3.1.1. All samples shall be tested as specified in paragraph 4. below.**
- 3.1.2. The kind of light sources on a LED MODULE shall be light-emitting diodes (LED) as defined in AIS 008 (Rev.1) paragraph 2.7.1.2 in particular with regard to the element of visible radiation. Other kinds of light sources are not permitted.**

3.2. OPERATING CONDITIONS

- 3.2.1. LED module operating conditions**

All samples shall be tested under the conditions as specified in paragraph 6.1.3. of this Standard. If not specified differently in this annex LED modules shall be tested inside the headlamp as submitted by the manufacturer.

3.2.2. Ambient temperature

For the measurement of electrical and photometric characteristics, the headlamp shall be operated in dry and still atmosphere at an ambient temperature of $23\text{ C} \pm 5\text{ C}$.

3.3. AGEING

Upon the request of the applicant the LED module shall be operated for 48 h and cooled down to ambient temperature before starting the tests as specified in this Standard.

4. SPECIFIC SPECIFICATIONS AND TESTS

4.1. COLOUR RENDERING

4.1.1. Red content

In addition to measurements as described in paragraph 7. of this Standard.:

The minimum red content of the light of a LED module or headlamp incorporating LED module(s) tested at 50 V shall be such that:

$$k_{\text{red}} = \frac{\int_{\lambda=610\text{ nm}}^{780\text{ nm}} E_e(\lambda) V(\lambda) d\lambda}{\int_{\lambda=380\text{ nm}}^{780\text{ nm}} E_e(\lambda) V(\lambda) d\lambda} \geq 0.05$$

where:

$E_e(\lambda)$ (unit: W) is the spectral distribution of the irradiance;

$V(\lambda)$ (unit: 1) is the spectral luminous efficiency;

λ (unit: nm) is the wavelength.

This value shall be calculated using intervals of one nanometre.

4.2. UV-RADIATION

The UV-radiation of a low-UV-type LED module shall be such that:

$$k_{UV} = \frac{\int_{\lambda = 250 \text{ nm}}^{400 \text{ nm}} E_e(\lambda) S(\lambda) d\lambda}{k_m \int_{\lambda = 380 \text{ nm}}^{780 \text{ nm}} E_v(\lambda) V(\lambda) d\lambda} \leq 10^{-5} \text{ W / lm}$$

where:

$S(\lambda)$ (unit: 1) is the spectral weighting function;

$k_m = 683 \text{ lm/W}$ is the maximum value of the luminous efficacy of radiation.

(For definitions of the other symbols see paragraph 4.1.1. above).

This value shall be calculated using intervals of one nanometer. The UV-radiation shall be weighted according to the values as indicated in the Table

UV below:

Table UV:

Values according to "IRPA/INIRC Guidelines on limits of exposure to ultraviolet radiation". Wavelengths (in nanometres) chosen are representative; other values should be interpolated.

λ	$S(\lambda)$	λ	$S(\lambda)$	λ	$S(\lambda)$
250	0.430	305	0.060	355	0.000 16
255	0.520	310	0.015	360	0.000 13
260	0.650	315	0.003	365	0.000 11
265	0.810	320	0.001	370	0.000 09
270	1.000	325	0.000 50	375	0.000 077
275	0.960	330	0.000 41	380	0.000 064
280	0.880	335	0.000 34	385	0.000 530
285	0.770	340	0.000 28	390	0.000 044
290	0.640	345	0.000 24	395	0.000 036
295	0.540	350	0.000 20	400	0.000 030
300	0.300				

4.3. TEMPERATURE STABILITY

4.3.1. Illuminance

4.3.1.1. A photometric measurement of the headlamp shall be made after 1 minute of operation for the specific function at the test point specified below. For these measurements, the aim can be approximate but shall be maintained for before and after ratio measurements.

Test points to be measured:

Principal passing beam 50 V

(For the measurement of bend lighting, the test point shall be specified by the manufacture.)

Driving beam H – V

4.3.1.2. The lamp shall continue operation until photometric stability has occurred. The moment at which the photometry is stable is defined as the point in time at which the variation of the photometric value is less than 3 per cent within any 15 minute period. After stability has occurred, aim for complete photometry shall be performed in accordance with requirements of specific device. Photometer the lamp at all test points required for the specific device.

4.3.1.3. 4.3.1.3. Calculate the ratio between the photometric test point value determined in paragraph 4.3.1.1. and the point value determined in paragraph 4.3.1.2.

4.3.1.4. Once stability of photometry has been achieved, apply the ratio calculated above to each of the remainder of the test points to create a new photometric table that describes the complete photometry based on one minute of operation.

4.3.1.5. The luminous intensity values, measured after one minute and after photometric stability has occurred, shall comply with the minimum and maximum requirements.

4.3.2. Colour

The colour of the light emitted measured after one minute and measured after photometric stability has been obtained, as described in paragraph 4.3.1.2. of this annex, shall both be within the required colour boundaries.

5. The measurement of the objective luminous flux of LED module(s) producing the principal passing beam shall be carried out as follows:

5.1. The LED module(s) shall be in the configuration as described in the technical specification as defined in Annex A. Optical elements (secondary optics) shall be removed by the test agency at the request of the applicant by the use of tools. This procedure and the conditions during the measurements as described below shall be described in the test report.

5.2. One module of each type shall be submitted by the applicant with the light source control gear, if applicable, and sufficient instructions.

Suitable thermal management (e.g. heat sink) may be provided, to simulate similar thermal conditions as in the corresponding headlamp application.

Before the test the LED module shall be aged at least for seventy-two hours under the same conditions as in the corresponding headlamp application.

In the case of use of an integrating sphere, the sphere shall have a minimum diameter of one meter, and at least ten times the maximum dimension of the

LED module, whichever is the largest. The flux measurements can also be performed by integration using a goniophotometer. The prescriptions in CIE–Publication 84 - 1989, regarding the room temperature, positioning, etc., shall be taken into consideration.

The LED module shall be burned in for approximately one hour in the closed sphere or goniophotometer.

The flux shall be measured after stability has occurred, as explained in paragraph 4.3.1.2. of this annex.

---XXX---